



INTERNATIONAL

Ferrite International . Pyroferric . TSC Bourgeois



TSC Ferrite International (Soft Ferrite Cores)

TSC Pyroferric (Iron Powder Cores)

TSC-bourgeois (Magnetic Laminations)

TSC International

TSC International is a manufacturer of magnetic materials for all frequencies. Our many end markets include: automotive, computer, lighting, telecommunications, instrumentation, industrial and consumer product industries across the United States and around the world.

Our objective is to provide the highest value magnetic products to our customers through a combination of exceptional *quality, delivery, service* and *price*. We offer speed to market with one stop shopping for materials for all frequencies along with engineering support.

TSC FERRITE International was established in 1985 as a division of Tempel Steel Company and was purchased by Tempel Smith in 1990. TSC Ferrite International purchased the assets of AVX/TPC Thomson, Beaune France in 2004. TSC Ferrite International produces MnZn and NiZn soft ferrites, which are electromagnetic material used as cores for high frequency (10KHz-10MHz) transformers and inductors.

TSC Pyroferric, founded in 1935, is the oldest manufacturer of iron powder cores in the United States. TSC acquired them in 1995, and they continue to manufacture iron powder cores for power conversion, line filter and RF applications.

In 1992 TSC Ferrite International purchased the assets of **TSC Arnold Technologies**, which was formerly known as The Lamination Division of the Arnold Engineering Company. TSC Arnold Technologies fabricates magnetic laminations by stamping. The laminations are used to make low frequency (dc-10KHz) inductors and transformers.

A Joint Venture between TSC International and r.bourgeois known as **TSC-bourgeois** was formed in 1998 to provide Laminations to the North American Motor and Automotive Industries.

In 1999 TSC International acquired Accucore from Magnetics International. **TSC Particle Core** is a new revolutionary magnetic material that offers an alternative to Laminations.

Combined, **TSC International** has >125,000 square feet of manufacturing space and >70 presses dedicated to meeting our market's demands.



TSC International

POLICY STATEMENT

MISSION STATEMENT & QUALITY POLICY

It is the policy of TSC International to provide the highest value magnetic materials to its customers through a combination of exceptional quality, price, delivery and service.

OBJECTIVES

1. **QUALITY:** Achieve and maintain a quality system consistent with ISO-9000:2004 International Standards. Produce magnetic materials within that quality system which satisfy our customers for quality and consistency and which meet or exceed the industry standards such as those of the Magnetic Materials Producers Association.
2. **PRICE:** Maintain cost control by encouraging innovation, having a flat organizational structure with individual empowerment at all levels and by expanding market share.
3. **DELIVERY:** Achieve speed-to-market by maintaining efficient administrative and productive systems, good internal communications and fast factory throughput.
4. **SERVICE:** Maintain excellent service by creating working partnerships with open lines of communication at all levels.
5. Resources will be dedicated to continuous improvement while ensuring a sustainable manufacturing process.

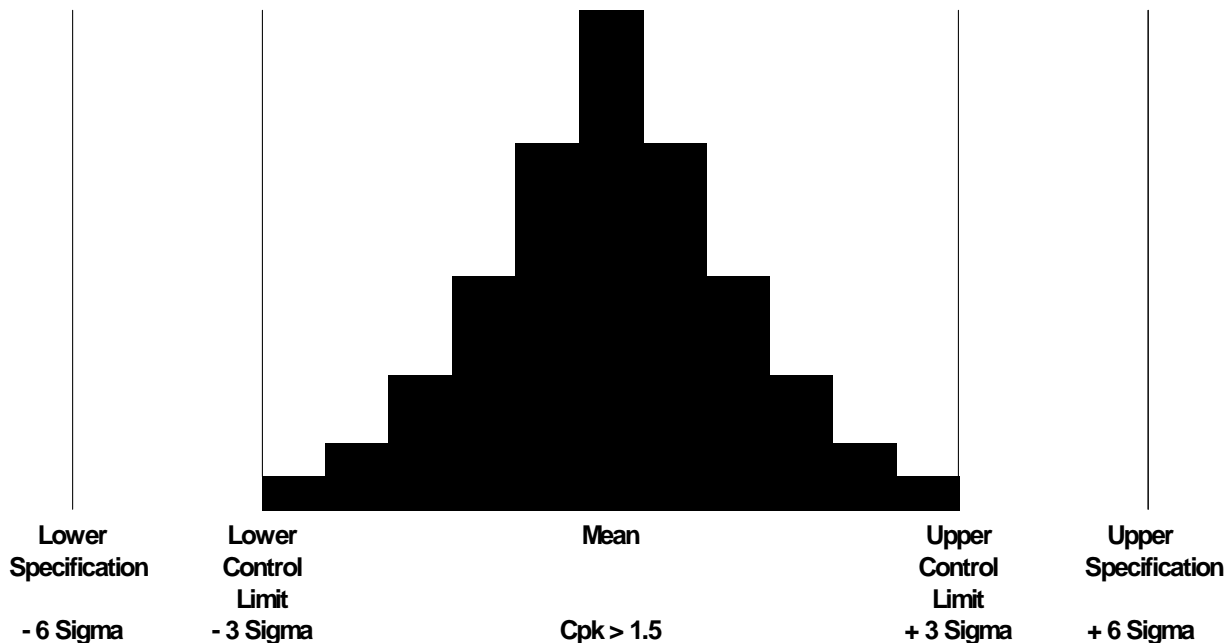

TSC International

INDEX

	Product Line	Page(s)
About TSC International	ALL	Inside Cover
Policy Statement	ALL	1
Index	ALL	2 & 3
Soft ferrite Manufacturing Overview	Soft ferrite	4
Definition of a soft ferrite	Soft ferrite	5
Test instrumentation	Soft ferrite	6
Ordering & Tolerances	Soft ferrite	7
Summary of soft ferrite material properties	Soft ferrite	8 & 9
TSF-50ALL (Flat Line)	Soft ferrite	10
TSF-5099	Soft ferrite	11
TSF-7099	Soft ferrite	12
TSF-7070	Soft ferrite	13
TSF-8040	Soft ferrite	14
TSF-5000	Soft ferrite	15
TSF-Boost	Soft ferrite	16 & 17
TSF-010K	Soft ferrite	18
Soft ferrite Part Numbering System	Soft ferrite	19
E cores	Soft ferrite	20 – 25
ETD Cores	Soft ferrite	26 & 27
Planar E	Soft ferrite	28
EFD Cores	Soft ferrite	29
PQ Cores	Soft ferrite	30
EP Cores	Soft ferrite	31
Pot Cores	Soft ferrite	32 & 33
U Cores	Soft ferrite	34 & 35
Toroids	Soft ferrite	36 & 37
Custom cores	Soft ferrite	38 & 39
Composite E Cores	Soft ferrite/iron powder	40 & 41
Composite Toroids	Soft ferrite/iron powder	42 & 43
Iron Powder Manufacturing Overview	Iron powder	44
Iron Powder Part Numbering System	Iron powder	44
Iron Powder Finish & Tolerances	Iron powder	45
Iron Powder Material Properties	Iron powder	46 – 50
Iron Powder Material & Part Number Cross Reference	Iron powder	51
Iron Powder Toroids for Power Conversions & Line Filter Applications	Iron powder	52 – 55

TSC International

INDEX (cont.)

	Product Line	Page(s)
Iron Powder E Cores	Iron powder	56
Iron Powder Material Properties for RF Applications	Iron powder	57
Iron Powder Toroids for RF Applications	Iron powder	58 & 59
Iron Powder Rod Cores	Iron powder	60 & 61
Iron Powder Thread Cores	Iron powder	62 – 66
Iron Powder Bobbin Cores	Iron powder	67 – 69
Lamination Material Properties	Laminations	70 – 73
EI Laminations	Laminations	74 & 75
E and Long E Laminations	Laminations	76
EE Laminations	Laminations	77
Core size selection for power transformers	ALL	78
Formulas Used to Design Magnetics	ALL	79
References	ALL	79
Glossary of Terms	ALL	80 & 81
Customary to Metric Conversions	ALL	82
Cross Reference of TSC International Parts	ALL	83
Formulas for Quality Metrics	ALL	84
Disclaimer & Warranties	ALL	84
Quality & Dimensional Metrics Conversions	ALL	Inside Back Cover

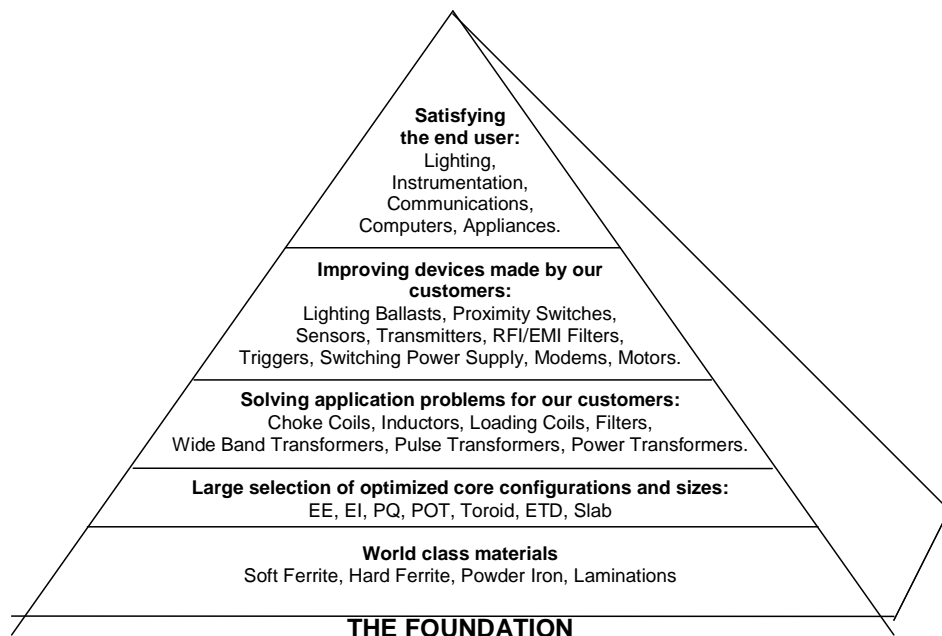

TSC Ferrite International

Ferrite Manufacturing Overview

<p>Test raw material (MnO, ZnO, Fe₂O₃) Inspect for purity ↓ Weigh & mix raw materials Control Composition ↓ Spray dry Obtain a powder form Control bulk density ↓ Calcine Powder (Pre-firing) Control magnetic saturation ↓ Wet mill Control particle size ↓ Spray dry to obtain a pressable powder Control bulk density ↓ Form (Compact powder into "green cores") Control pressed density ↓ Sinter (fire "green cores" to obtain a ceramic with a spinel crystal lattice structure) Control grain growth ↓ Finish (grind, tumble, coat) Control gap and surface finish ↓ Audit to insure that all parts meet all the customers requirements ↓ Pack & Ship</p>	<p>The process of manufacturing Soft Ferrites is made up of four basic steps: powder preparation, forming, sintering and finishing. At Ferrite International raw materials (manganese oxide, zinc oxide and iron oxide) are tested for purity levels. After the raw materials are approved they are weighed and wet mixed, and spray dried to a powder form then calcined. Calcining is pre-firing the material at a selected temperature between 800 degrees and 1100 degrees C thus creating a partial spinel structure and partially densifying the powder so that the pressed part will shrink less during the final sintering process. The calcined material is then wet milled to a specific particle size range. This particle size reduction enables better control of grain growth that occurs during the final sintering process. An organic binding agent is added to the slurry for the purpose of holding the pressed part intact. The slurry is then spray dried to provide a dry moldable powder composed of discreet spherical agglomerates with uniform characteristics.</p> <p>The forming operation transforms the powder into a soft "clay like" material in the desired configuration. In this form they are called "green cores". The forming is done using presses and powder compaction tools. Because tool steels do not last under the wear of the abrasive Ferrite powder, carbide tools are used for large quantity items. The size, weight and thus the density of the green compact are all controlled within very tight tolerances.</p> <p>To create the desired physical and magnetic characteristics the "green cores" are sintered in large kilns at temperatures between 1300 and 1450 degrees Centigrade. Close temperature and atmospheric control during sintering is critical. The sintering is divided into three stages. In the first stage the binders are driven off. The second stage is when the actual sintering takes place. The spinal crystal latus structure forms, the product shrinks and the magnetic characteristics are realized. The final stage is devoted to reoxidation and cool-down. Volume shrinkage is affected by the size, shape and the chemical composition. Each part must be molded oversize. A typical material may shrink 15% in any one linear dimension (approximately 50% of total volume).</p> <p>Cores that will be assembled require machining. This process is critical to removing the final surface layer of reactive Ferrite (called skin) that result from sintering and to minimize any air gaps by insuring smooth flat and parallel surfaces. Some cores sets require gaps with tight tolerances in their flux path. This can be accomplished by grinding a pot core's center post or an E core's center leg. Because of the extremely hard, brittle and abrasive nature of the ceramic material diamond wheels and large amounts of liquid coolant are required for all machining operations.</p> <p>Sintered toroidal cores are tumbled and sometimes coated with epoxy to eliminate any sharp corners or burrs that could damage wire insulation during the ensuing operation.</p> <p>Finally the cores are tested electrically, inspected for dimensional and visual conformance and packed to be shipped to our customer.</p>
---	---

TSC Ferrite International

Definition of a soft ferrite core

Soft Ferrites are ceramic electromagnetic material dark gray or black in appearance and very hard and brittle. The terms "SOFT" has nothing to do with their physical properties but refers to their magnetic characteristics. Soft magnetic materials also called electromagnetic exhibit magnetic properties only when they are subject to a magnetizing force such as the magnetic field created when current is passed through wire surrounding a soft magnetic core. This differs from hard magnetic (Permanent Magnets) in that once a hard magnetic material is magnetized by exposure to a magnetizing force it exhibits magnetic properties permanently.

A Soft Ferrite's magnetic properties arise from interactions between metallic ions occupying particular positions relative to the oxygen ions in its spinel crystalline structure. The magnetic domain theory suggests these interactions create magnetic domains, which are microscopic magnetized regions within the material. When no magnetizing force is present the magnetic domains are random and the net flux contribution is zero even though local domains are fully magnetized. When a magnetizing force is present the magnetic domains align in the direction of the magnetizing force resulting in a large net flux contribution.

Soft Ferrites are also semi-conductors meaning they are somewhere between conductors and insulators in their ability to conduct electron flow through the material.

Advantages Soft Ferrites have over other electro magnetic materials include their inherent high resistivity, which results in low eddy current losses over wide frequency ranges, high permeability and stability over wide temperature ranges. For inductor cores, transformer cores and other applications where electro magnetic materials are required to operate at high frequencies these advantages make Soft Ferrites paramount over all other magnetic materials.

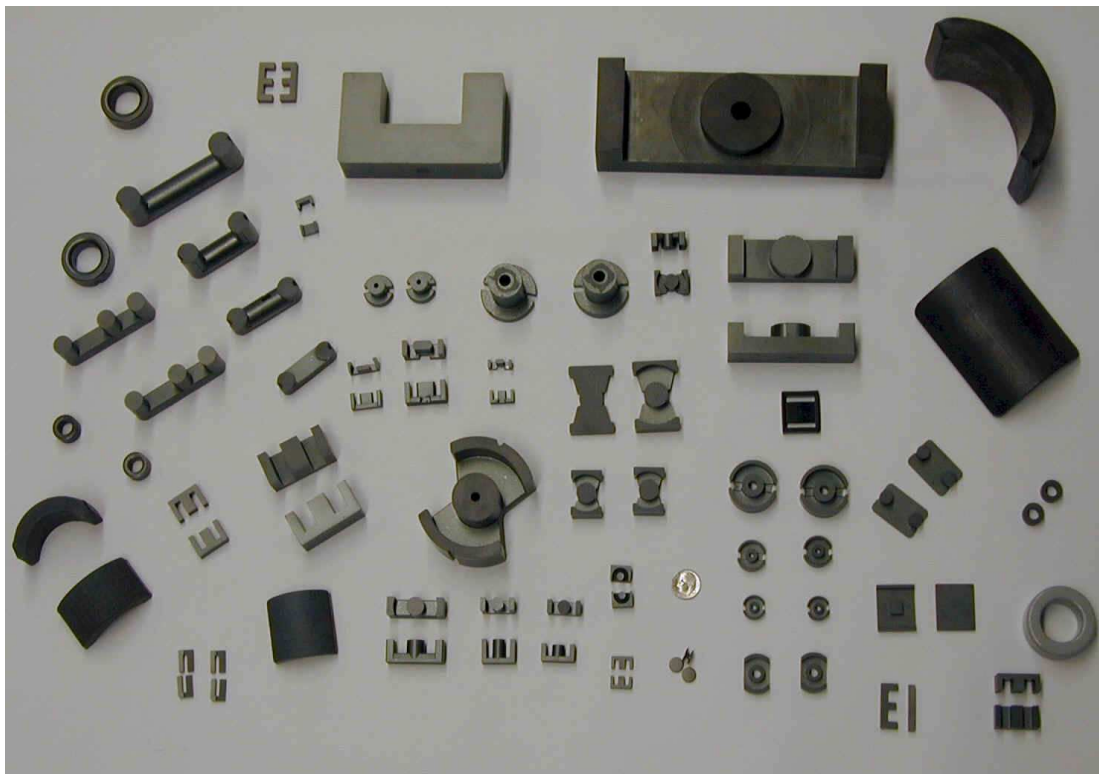

TSC Ferrite International

Test Instrumentation & Methods

Core Loss

Published values of core loss have been measured on E21 size (41-16-12) double E cores. The cores are driven with an ENI Model 2100L RF Amplifier and measured using Clarke-Hess Model 2335 VAW meters under sine wave conditions. Flux densities were calculated using rms voltage values and effective core set parameters calculated per MMPA standard No. EUI310. Core loss density was calculated per the same standard. These curves are applicable to all sizes and configurations as long as the correct effective core set parameters are assumed. Data and graphical curves of core loss vs. temperature measured on ungapped core sets are included for each kiln firing and lot with each shipment of our products.

Initial Permeability

Published values of initial permeability have been calculated from measured inductance values at 5 gauss on toroids (OD=.870, ID=.540, HT=.250) using Wayne-Kerr model 6425 or model 3245 LCR meters. Flux density and permeability were both calculated using effective core set parameters (Le, Ae and Ve) calculated per MMPA Toroid Standard No. FTC410.

Power Permeability

(Permeability vs. Flux Density)

Published values of Power Permeability have been calculated from measured values of rms currents and voltages on 25-10-06 size double E cores using Clarke-Hess model 2335 VAW meters.

$$\mu = (L / L_{air}) = ((0.45 * E_{rms}) / (f * I_{rms} * 2.829)) / ((0.004 * \pi * A_e * 10^{-6}) / L_e)$$

Saturation Flux Density

Published values of saturation flux density have been calculated from integrated voltage measurements on 25-10-06 size double E cores induced by a specific magnetizing force (15 oersteds).

Inductance Index (AL Value)

Published AL Values were measured on Wayne-Kerr model 6425 or model 3245 LCR meters using 100 turn coils. Mated cores have a clamp pressure of approximately 5 pounds per square inch of mating surface. Statistical data including a histogram and capability indexes of the AL value on gapped and ungapped core sets are included with each shipment of our products.

Total Harmonic Distortion

We measure harmonic distortion on an Audio Precision System Two (SYS-2022) in accordance to our customer's part specific specification. The test circuit primary series resistance, output load resistance, frequency and drive level in Db, Vrms or Vpp are specified by our customers.

TSC Ferrite International

Ordering Gapped Cores

Gapped Cores can be ordered 3 ways:

1. To a mechanical dimension.
2. Two gapped cores mated together to yield a specific AL value.
3. One gapped core mated with one ungapped core to yield a specific AL value.

When ordering cores to an AL value, it is important to specify whether 2 gapped cores are mated together or if 1 gapped core is mated with 1 ungapped core. It is also helpful if each customer supplies us with their coil to avoid differences in fringing flux that would result in a difference in AL measurements between the customer and the manufacturer. On our throughput grinder, we are capable of holding mechanical gap tolerances of $\pm .0007$ ". Because the relationship between AL and gap depth is a decaying exponential, the AL tolerance we are capable of is dependent upon the depth of the gap (larger gaps yield smaller AL values with tighter tolerances than do smaller gaps).

Tolerances

Problems periodically arise concerning magnetic and mechanical tolerances of ferrites. The nominal and spread of a sample lot is not always indicative of production lots. As an example, toroids are supplied to a nominal AL value based on material grade, and a tolerance of $\pm 25\%$. The nominal AL value for a large number of production lots is considered to be at 0.0%, then the total spread of a large number of shipments will be $\pm 25\%$ around this nominal.

Sample parts with given characteristics positioned at some desired point within the normal spread cannot be easily produced because chemical processes cannot be controlled this closely. For this reason, it is difficult to fill requests for "maximum" and "minimum" samples. Every TSC Ferrite International sample is supplied with data showing our measured values on each sample compared to the specification upper and lower limits.



TSC Ferrite International

Material Grade	Initial Permeability	Saturation Flux Density @15 oersteds	Curie Temperature	
	μ_0	B_s (Gauss)	T_c (°C)	
TSF-50ALL "Flat Line" ASTM P5025-100	3,000	5,000	>230	Low loss & stable perm over wide temperature range
TSF-5099 ASTM P5099	2,000	5,000	>210	Low core loss
TSF-7099 ASTM P7099	2,000	5,000	>210	For high ambient temperature applications
TSF-7070 ASTM P7070	2,200	5,000	>210	For potted applications
TSF-8040 ASTM P8040 ASTMF3000	3,100	5,100	>210	All purpose material for integrated magnetics
TSF-5000 ASTM F5000	5,000	4,300	>170	For filter inductors
TSF-010K ASTM F010K	10,000	4,300	>125	For low harmonic distortion
TSF-Boost	2,000	5,000	>210	For dc bias applications
TSF-0850	850	3,000	~140	NiZn for suppression of 30MHz to 200MHz signals
TSF-0125	125	3600	~350	NiZn usable permeability up to 100MHz
TSF-0040	40	2,600	~450	NiZn usable permeability up to 300MHz

Soft Ferrite Material Constants

Specific Heat	0.25 cal / g / °C
Thermal Conductivity	10×10^{-3} cal / sec / cm / °C
Coefficient of Linear Expansion	8 to 10×10^{-6} / °C
Tensile Strength	7×10^3 lbs / in ²
Compressive Strength	60×10^3 lbs / in ²
Young's Modules	18×10^3 lbs / in ²
Hardness (Knoop)	650
Density	4.8 g / cm ³

TSC Ferrite International

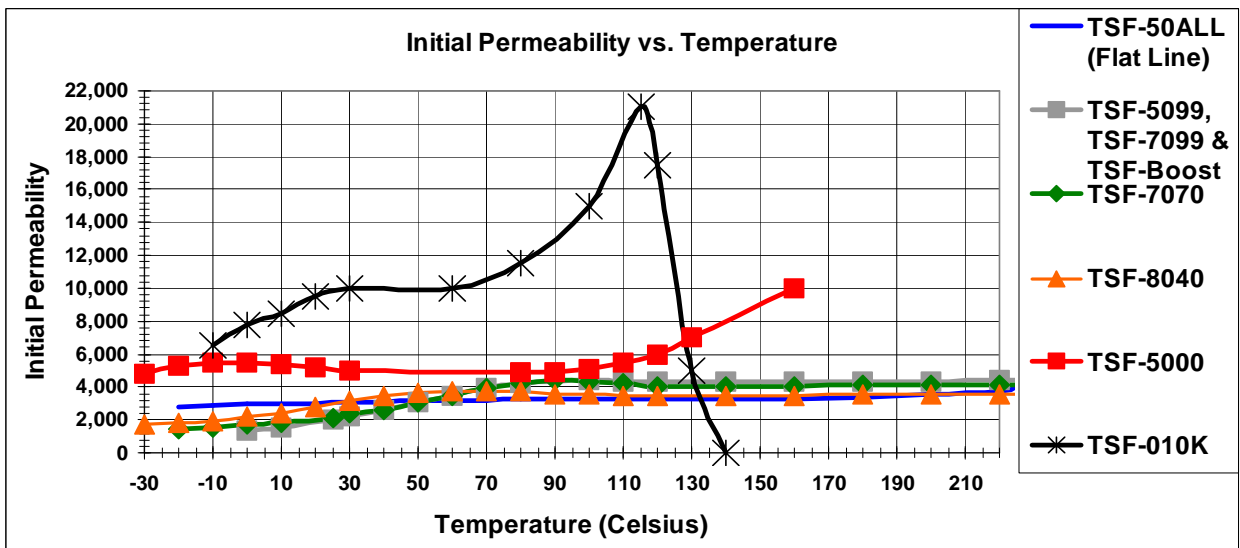
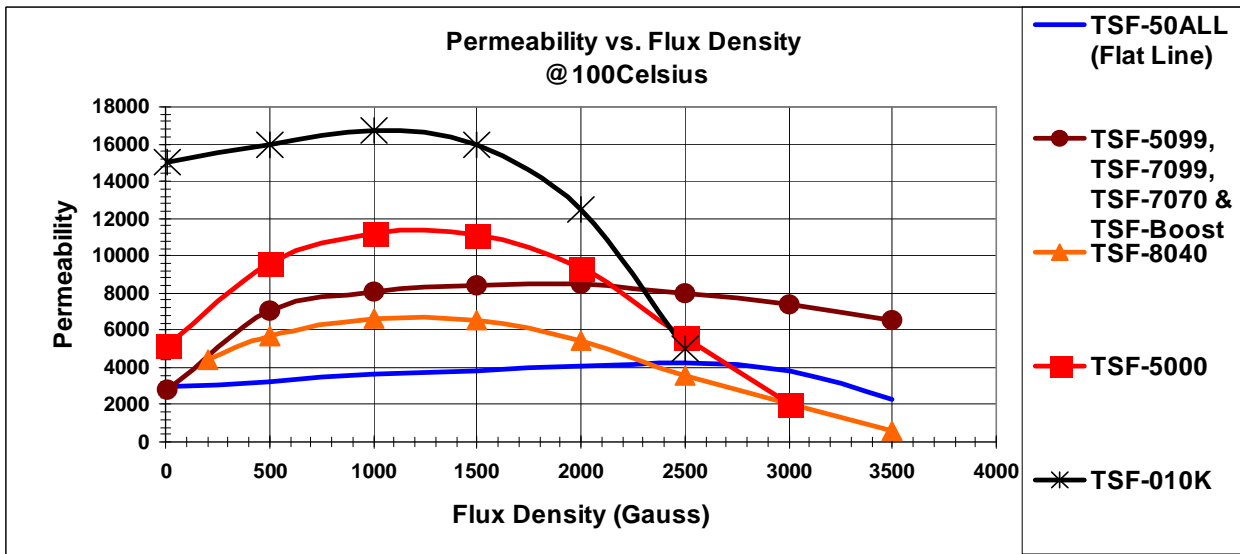
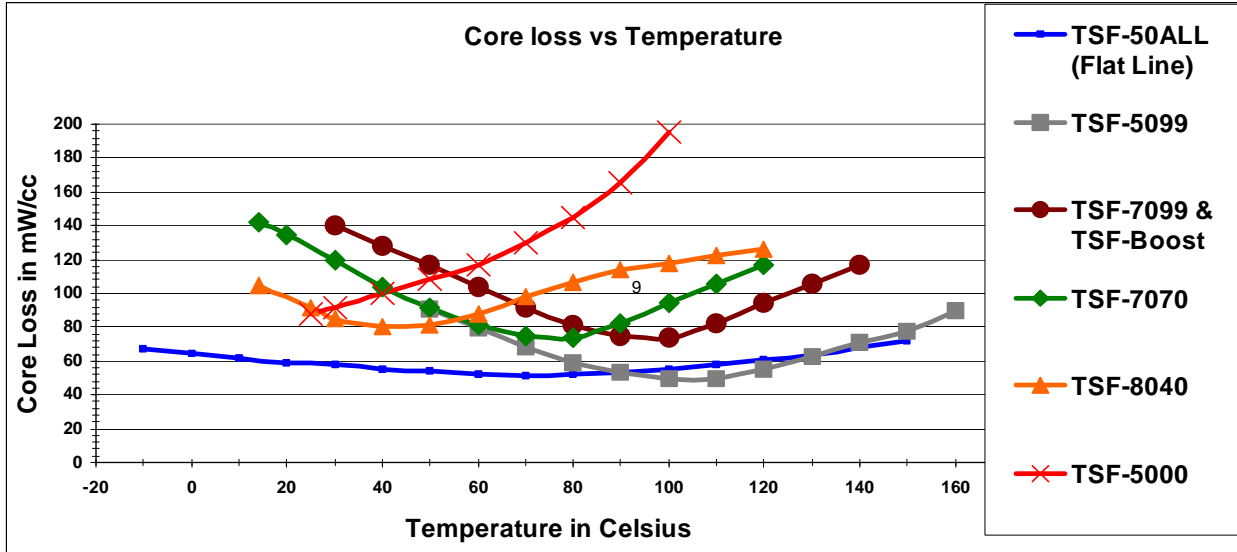

TSC Ferrite International

ASTM Material Type P5025-100
 TSC Ferrite Material Grade TSF-50ALL Flat Line
 Stable low core loss & stable permeability over wide temperature range
 Initial Permeability 3,000 +/-25%
 Curie Temperature >230 Celsius
 Core Loss Density = $P_c = 0.08 f^{1.39} B^{2.91}$ in mW/cc 25 through 100 Celsius

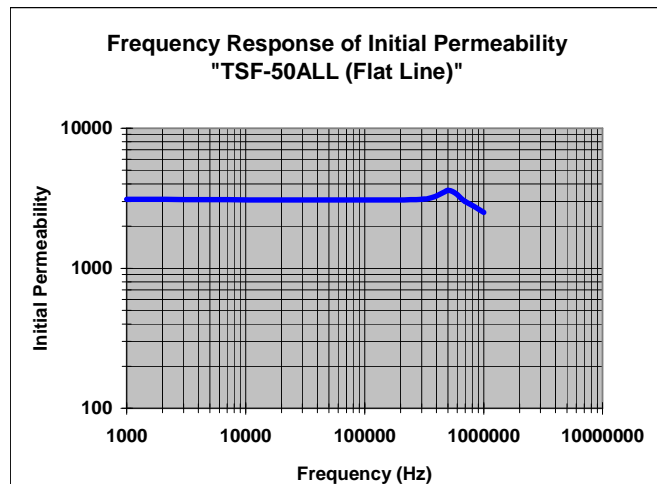
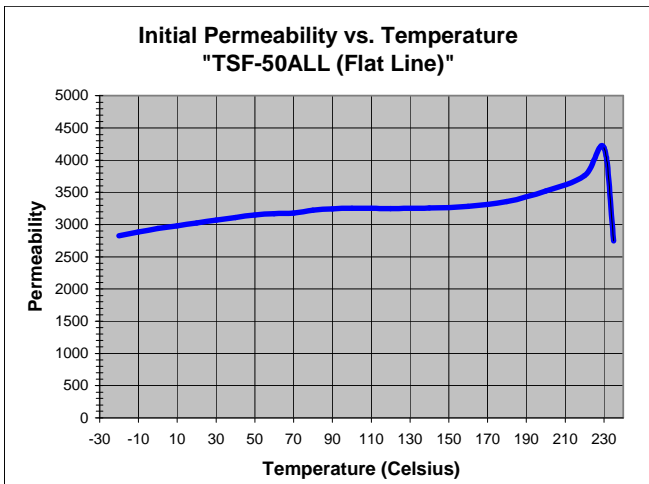
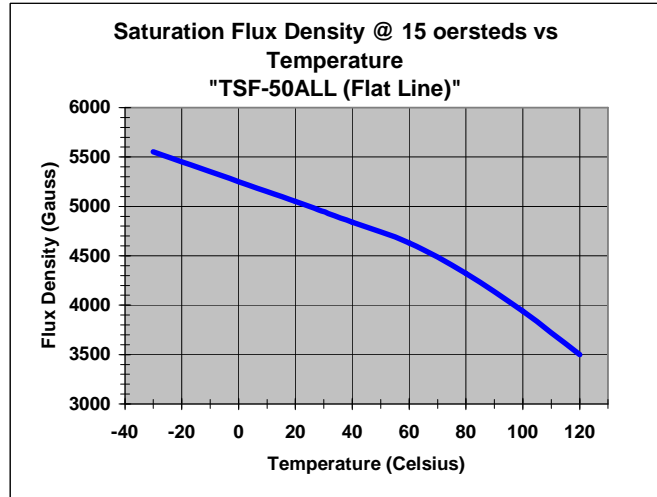
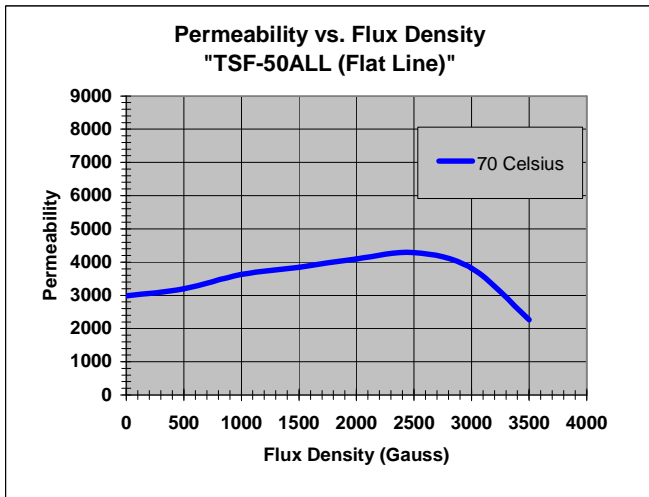
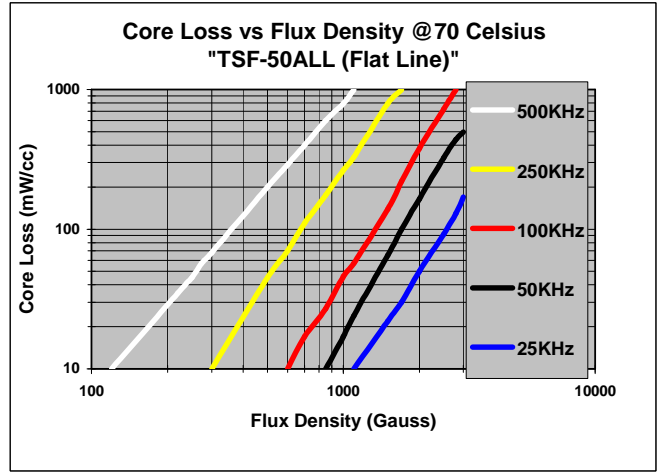
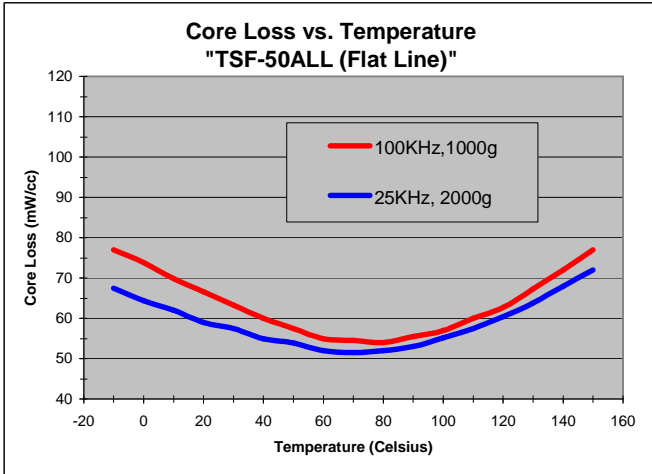

TSC Ferrite International

ASTM Material Type P5099
 TSC Ferrite Material Grade TSF-5099
 Extremely Low Core Loss, minimum at 100 Celsius
 Initial Permeability 2,000 +/-25%
 Curie Temperature >210 Celsius

Core Loss Density = $P_c = 0.08 f^{1.39} B^{2.91}$ in mW/cc at 100 Celsius

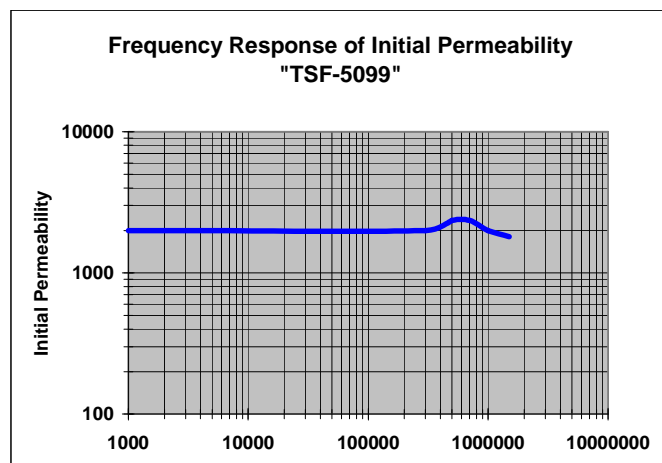
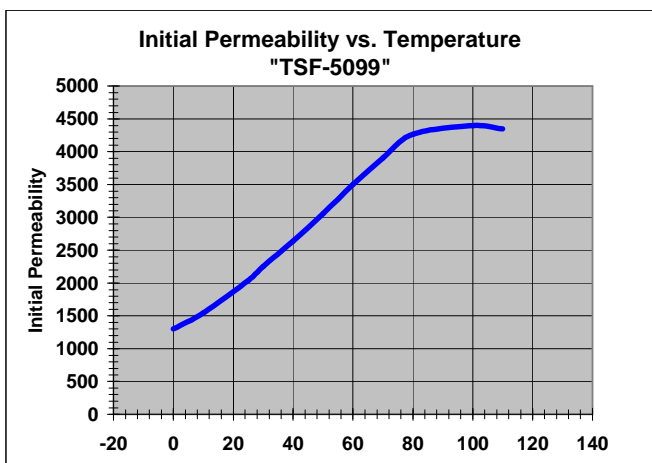
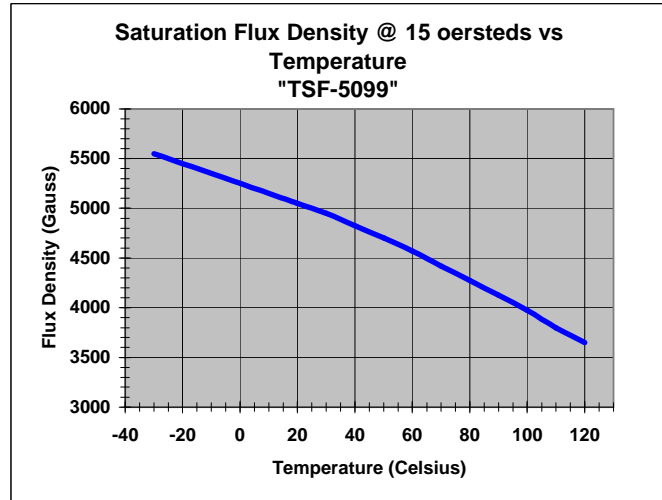
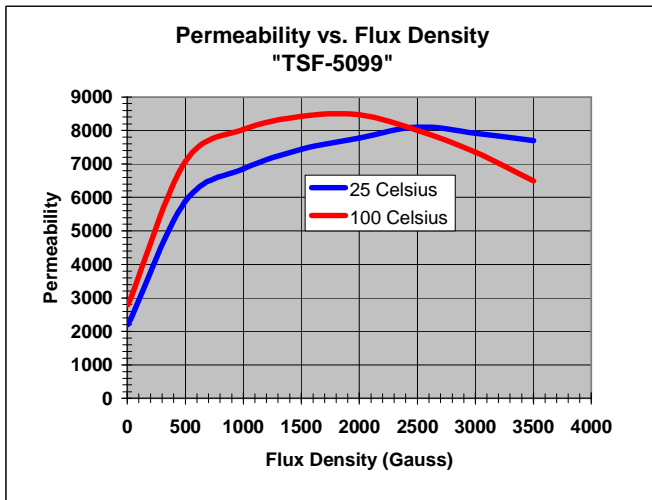
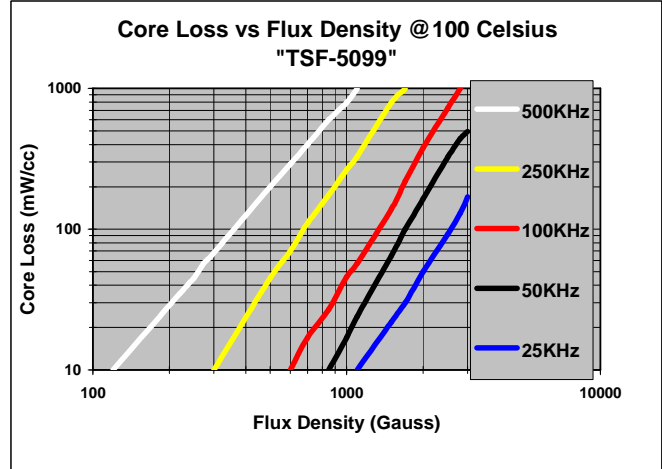
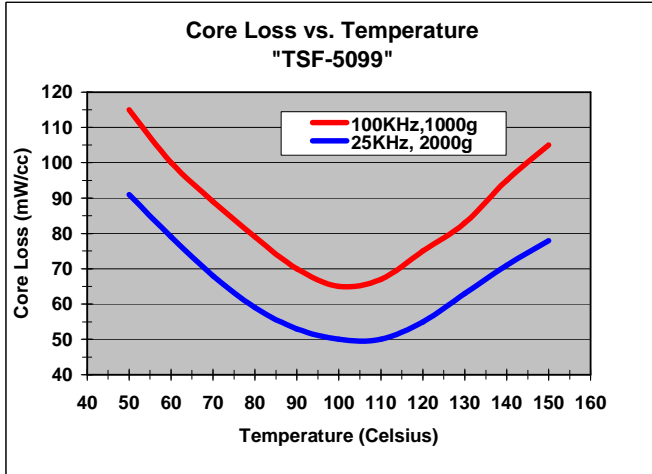

TSC Ferrite International

ASTM Material Type P7099
 TSC Ferrite Material Grade TSF-7099
 Low Core Loss, minimum at 100 Celsius
 Initial Permeability 2,000 +/-25%
 Curie Temperature >210 Celsius

Core Loss Density = $P_c = 0.147 f^{1.34} B^{2.54}$ in mW/cc at 100 Celsius

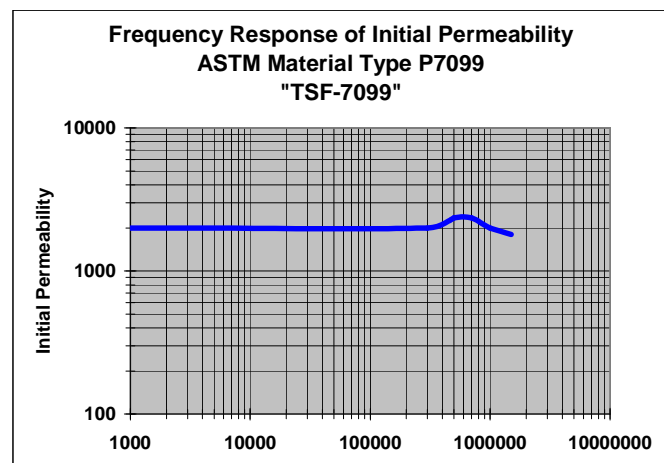
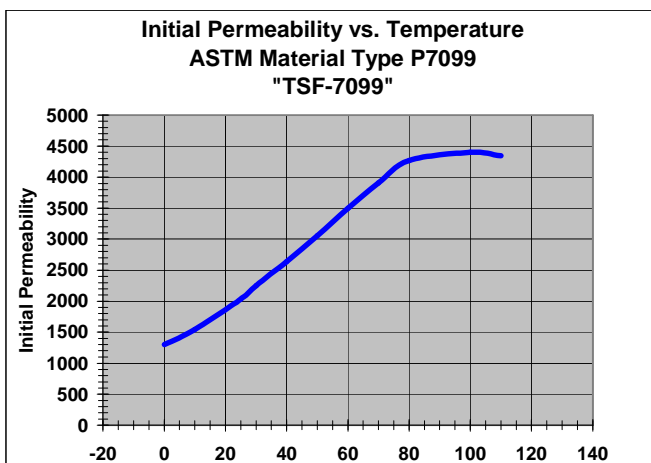
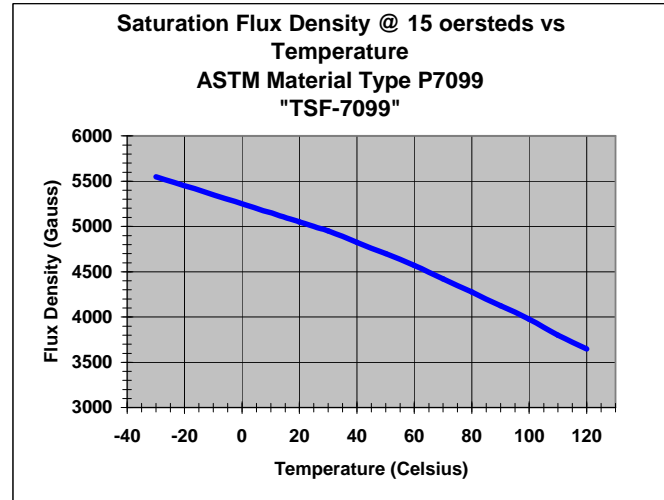
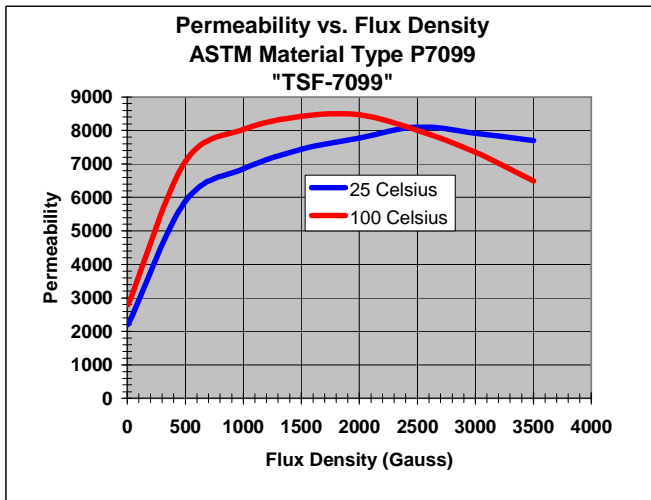
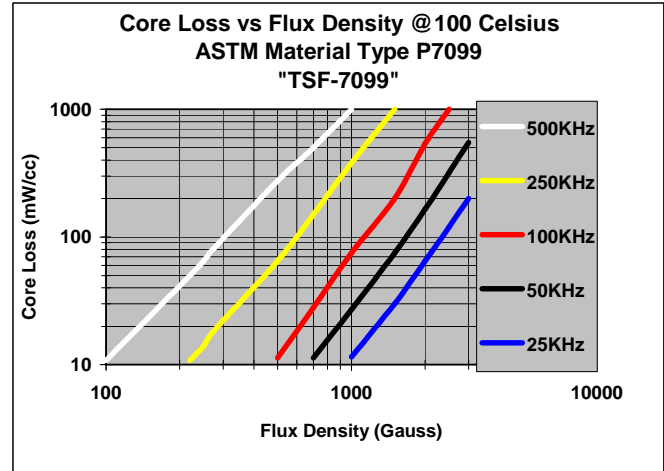
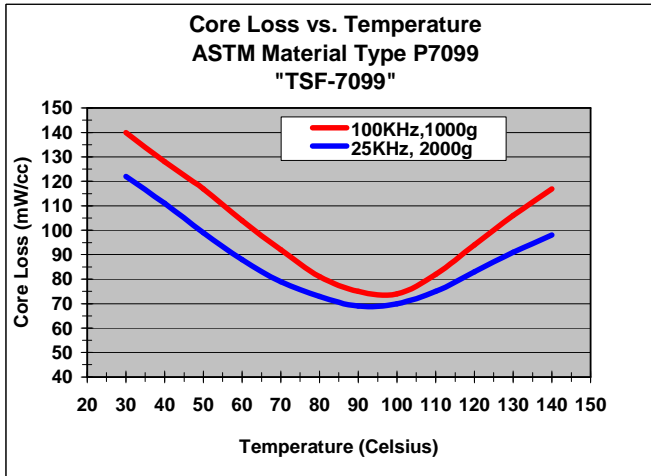

TSC Ferrite International

ASTM Material Type P7070
 TSC Ferrite Material Grade TSF-7070
 Low Core Loss, minimum at 70 Celsius
 Initial Permeability 2,200 +/-20%
 Curie Temperature >210 Celsius

$$\text{Core Loss Density} = P_c = 0.147 f^{1.34} B^{2.54} \text{ in mW/cc at 70 Celsius}$$

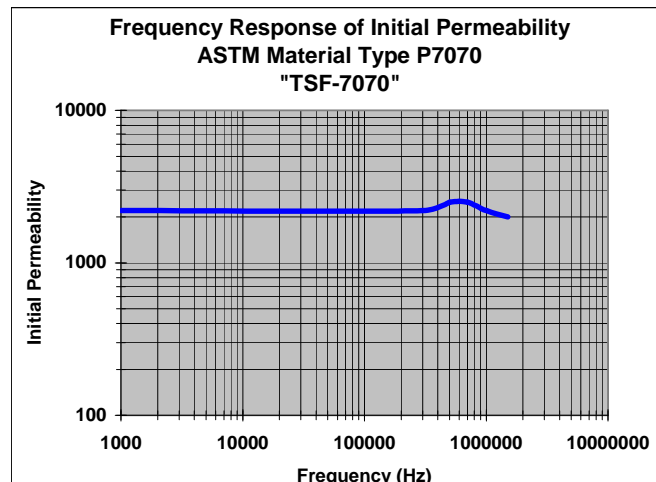
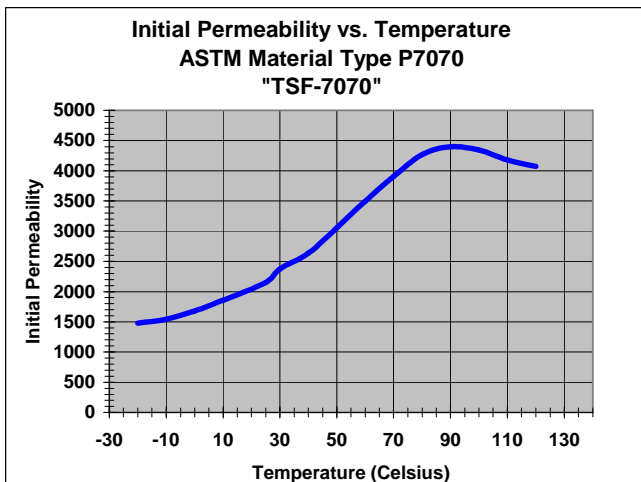
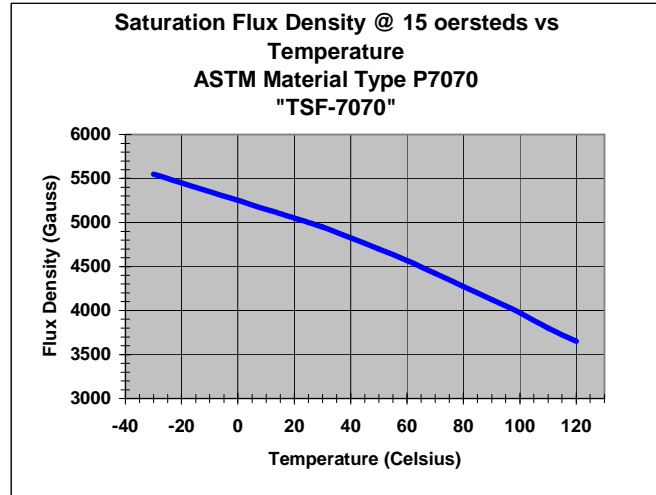
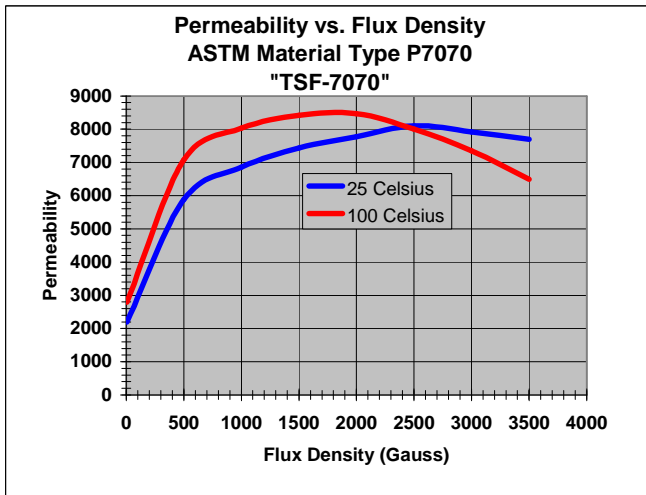
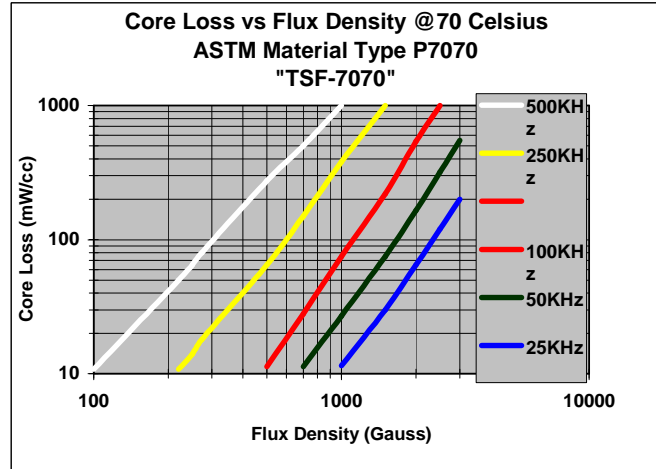
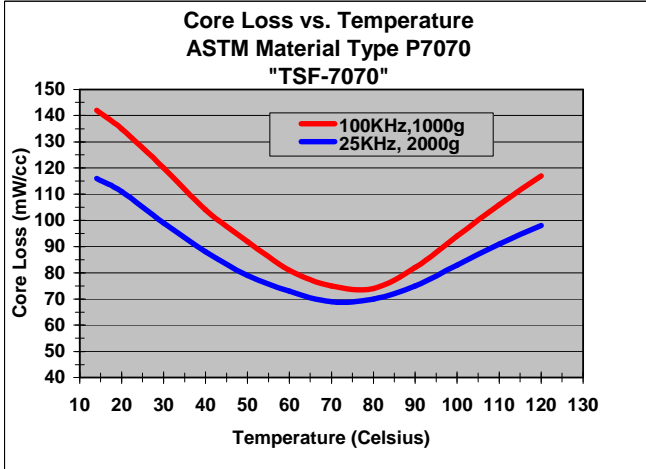

TSC Ferrite International

ASTM Material Types P8040 & F3000
 TSC Ferrite Material Grade TSF-8040
 All purpose material for integrated magnetics
 Initial Permeability 3,000 +/-25%
 Curie Temperature >210 Celsius

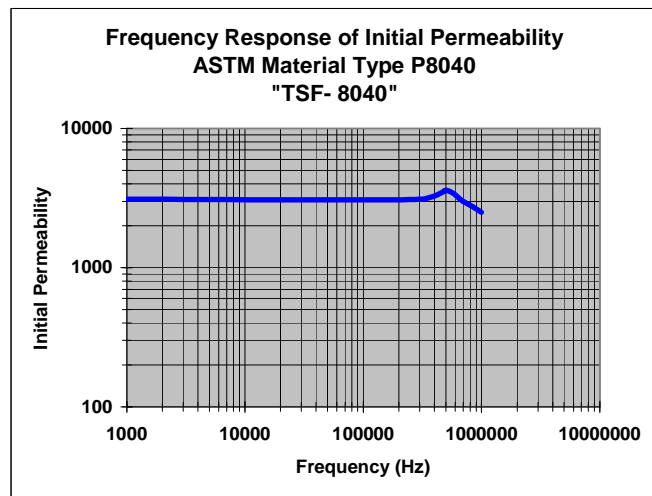
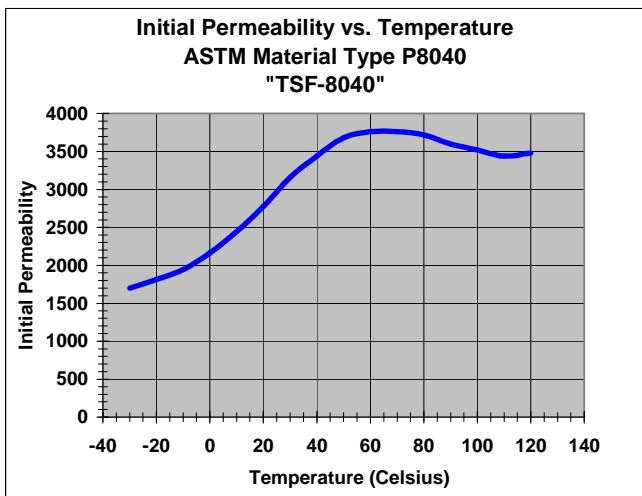
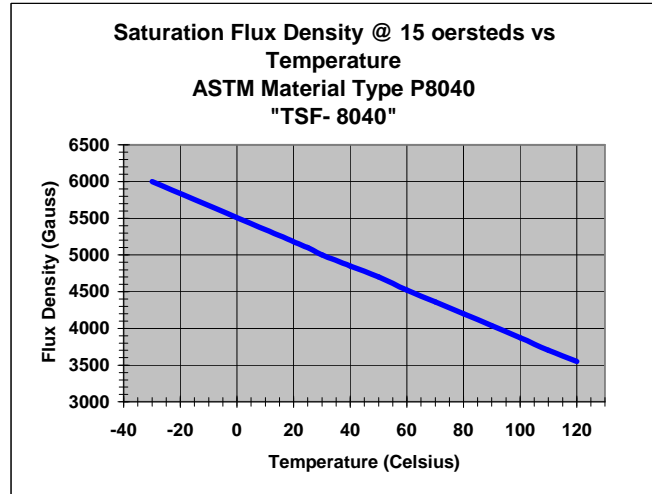
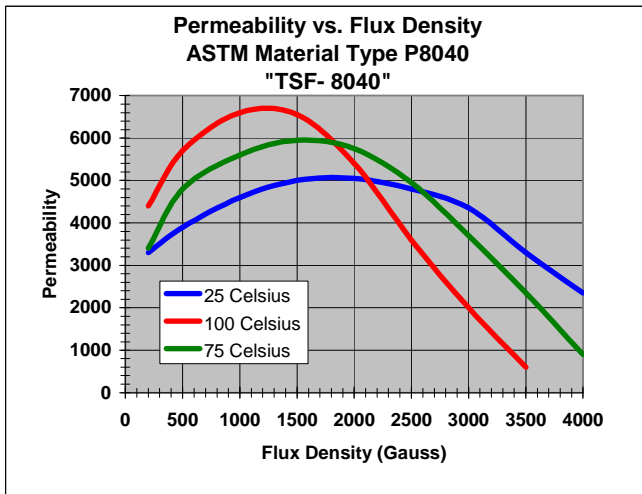
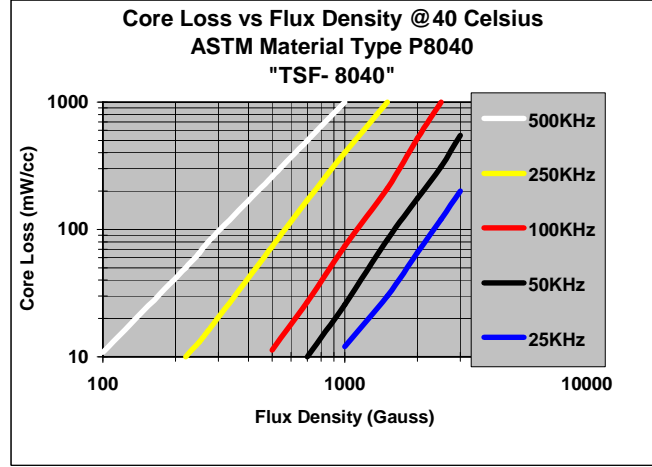
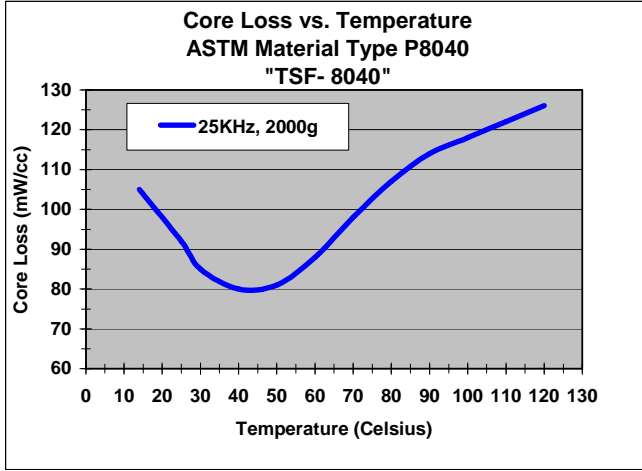

TSC Ferrite International

ASTM Material Type F5000
 TSC Ferrite Material Grade TSF-5000
 Filter material for input inductors & pulse transformers
 Initial Permeability 5,000 +/-25%
 Curie Temperature >170 Celsius

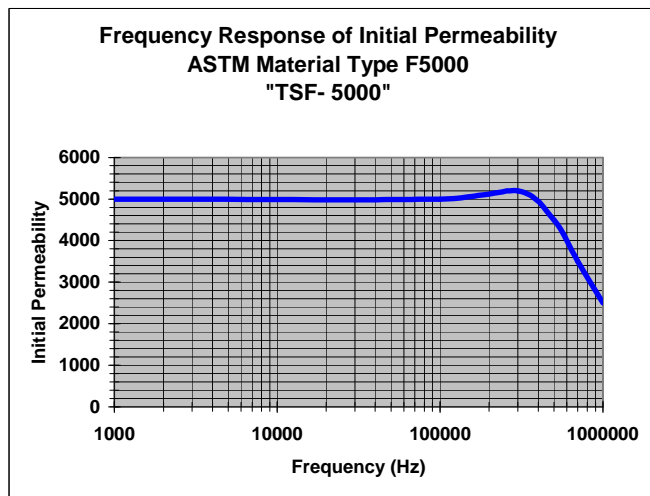
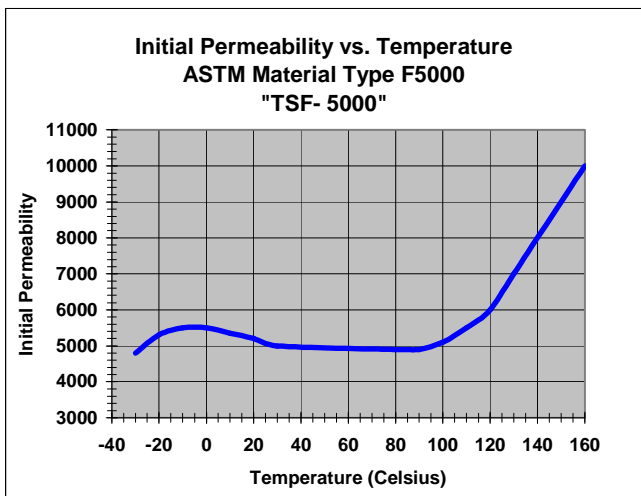
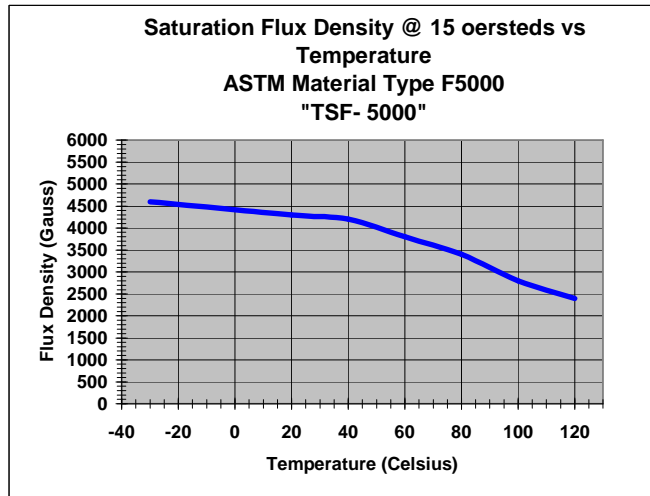
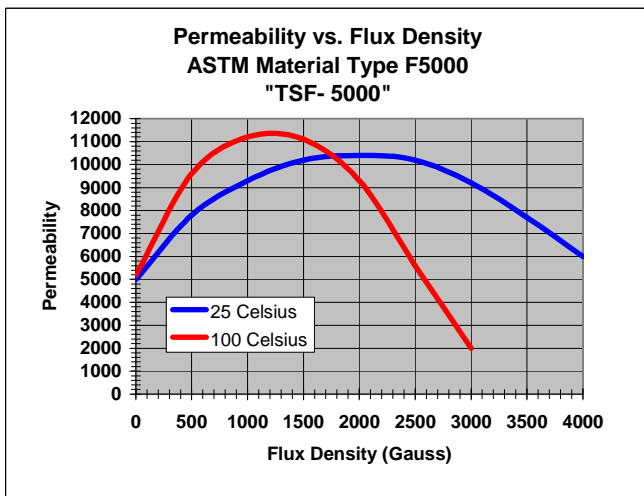
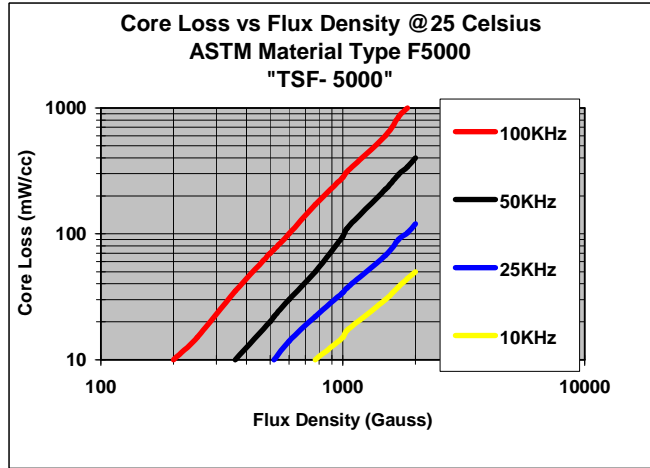
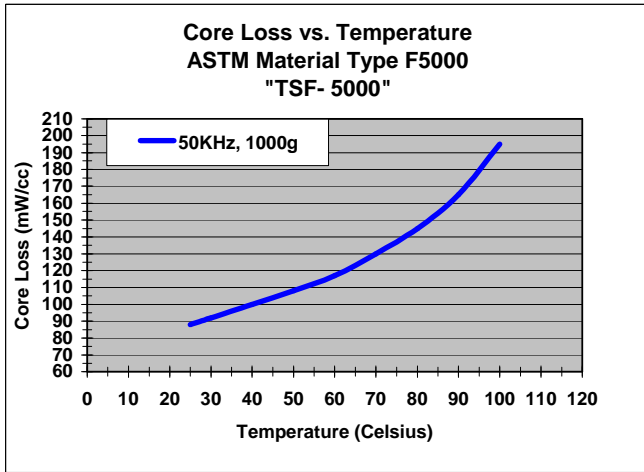

TSC Ferrite International

TSC Ferrite Material Grade TSF-Boost

High Saturation Flux for flyback transformers and output inductors that need to support large bias current
 Initial Permeability 2,000 +-25%
 Curie Temperature >210 Celsius

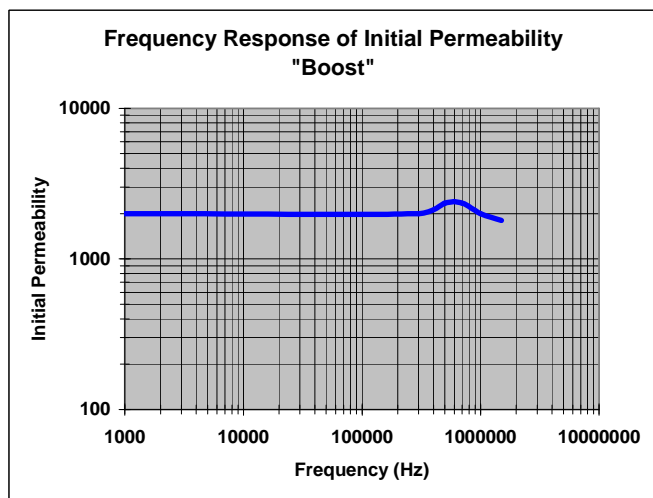
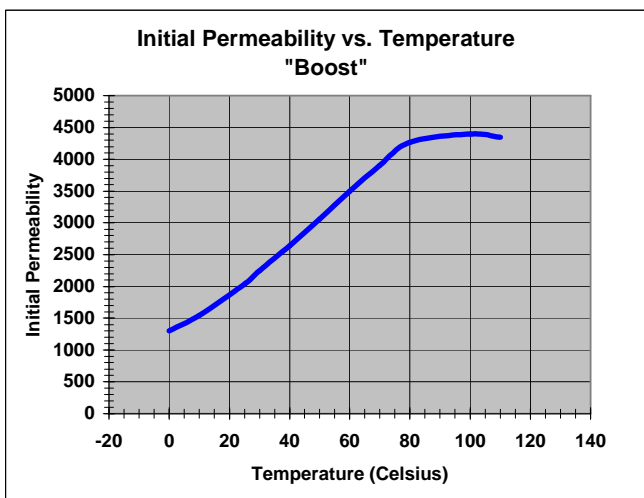
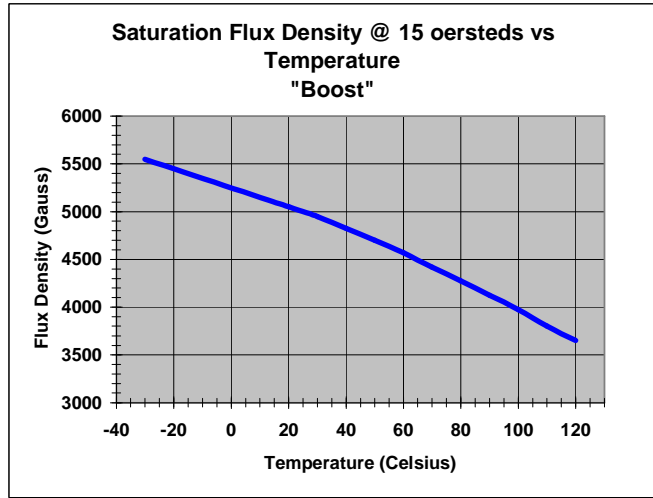
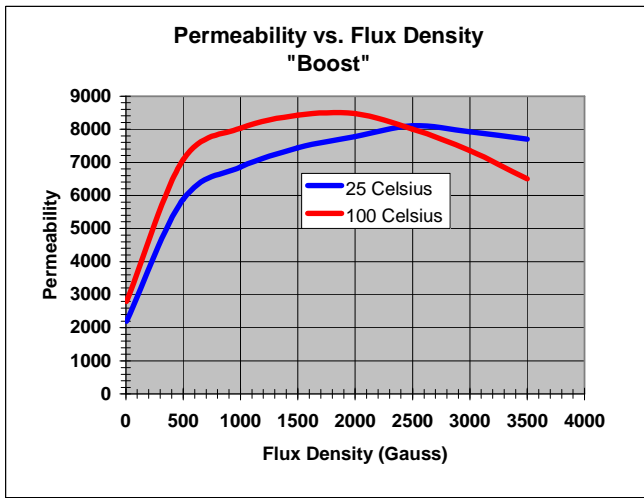
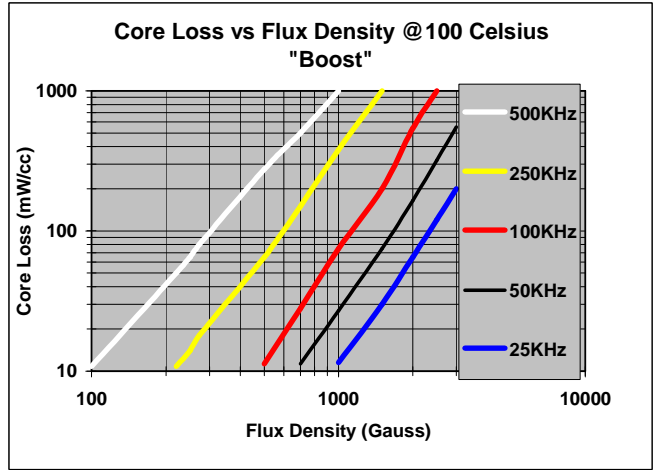
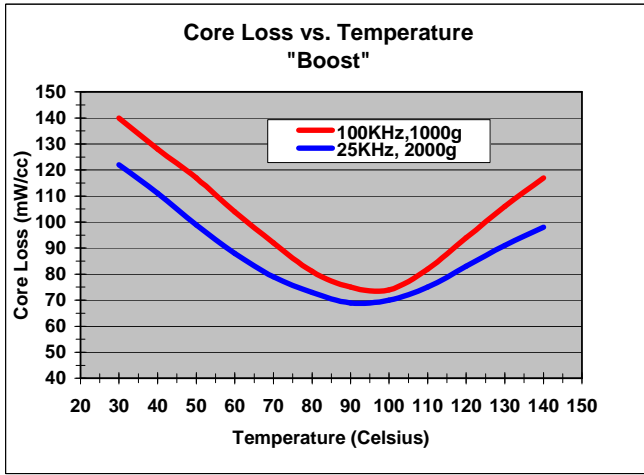

TSC Ferrite International

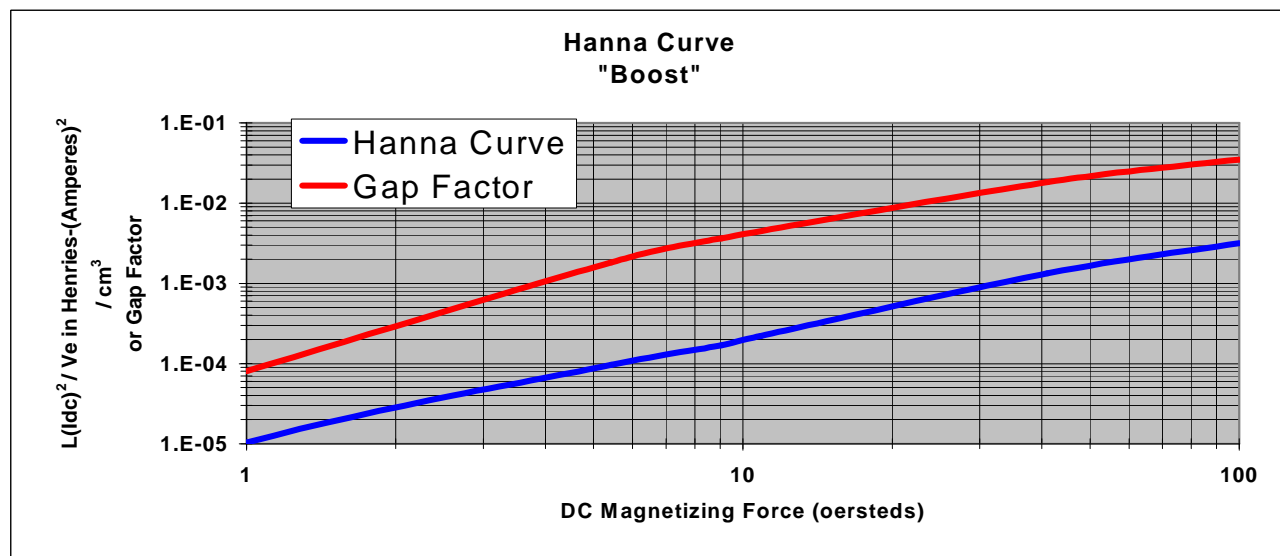
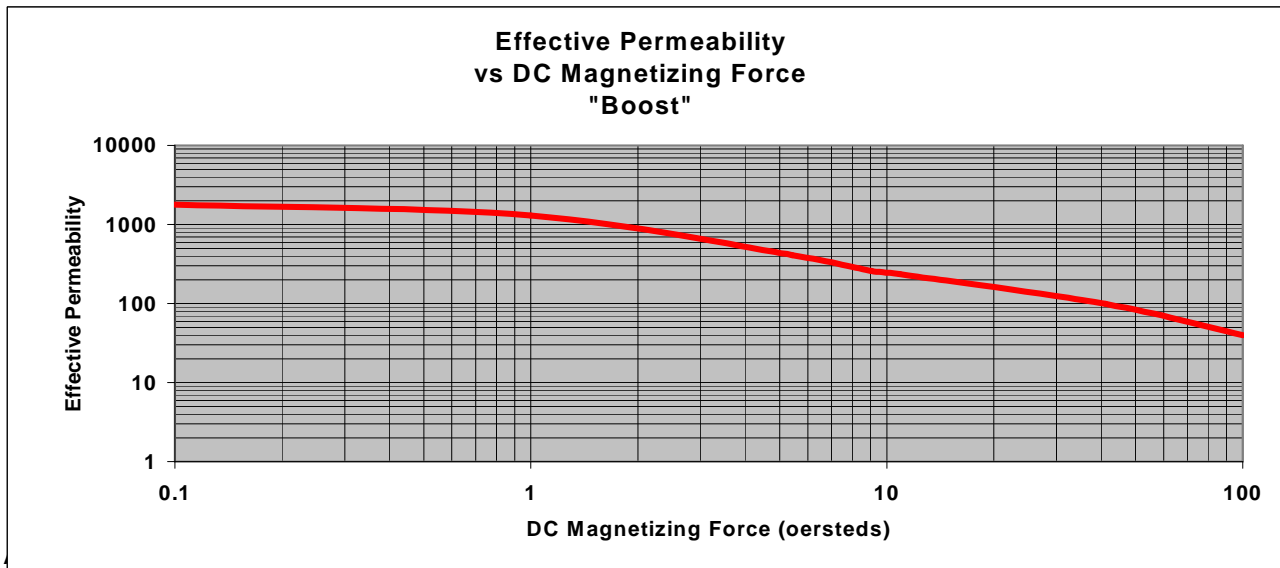

Above graph represents the maximum DC bias field with no more than 10% reduction in inductance

Calculate $L(I_{dc})^2 / V_e$ in Henries-Amperes²/cm³

Read DC Magnetizing force (H in oersteds) at the value where $(L(I_{dc})^2 / V_e)$ intersects Hanna Curve

Calculate Turns $N = (H L_e) / (0.4 \pi I_{dc})$

Calculate Gap = (Gap Factor) $(L_e / 2.54)$

L = desired Inductance in Henries

I_{dc} = dc bias current in amps

V_e = effective core volume in cm³

N = turns on coil

H = magnetizing force in oersteds from Hanna Curve

L_e = magnetic path length in cm

Gap = core gap in inches

Gap Factor = value from gap factor curve at same DC Magnetizing Force as Hanna curve

TSC Ferrite International

ASTM Material Type F010K
TSC Ferrite Material Grade TSF-010K
Filter material for input inductors
Initial Permeability 10,000 +30%
Curie Temperature >125 Celsius

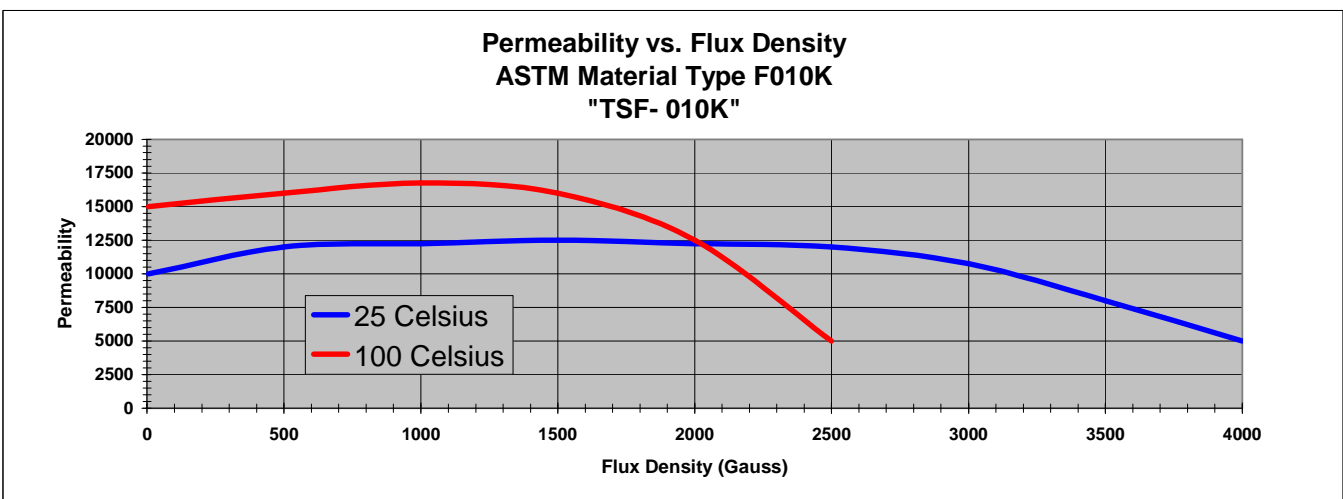
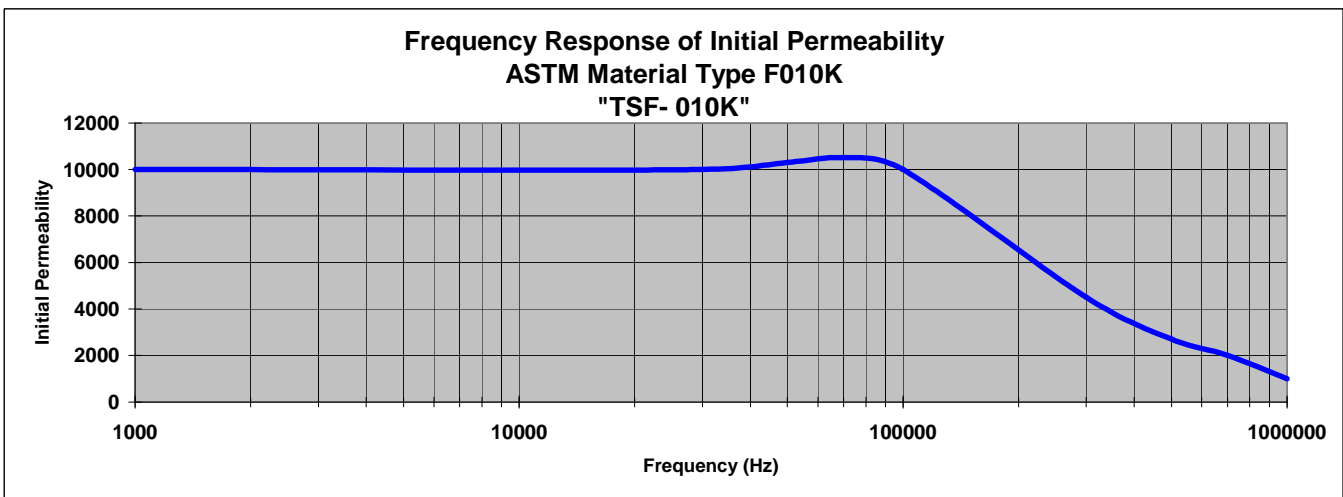
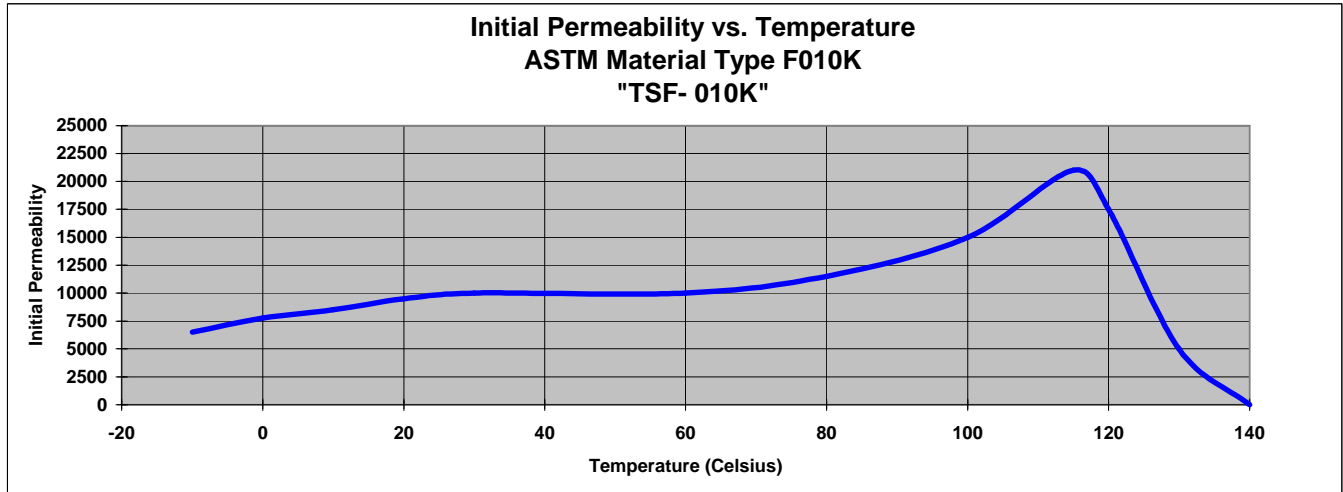

TSC Ferrite International

FERRITE PART NUMBERING SYSTEM

Our material grade names have been chosen to make them meaningful to our customers.

These meaningful grade names, like the meaningful dimensional portion of our part numbering system, are meant to help our customers identify important characteristics of our parts by the part number alone.

TSF-50ALL
Temperature of low core loss (<room to >100°C)
Core loss at 100KHz, 1000 gauss (50 mw/cm³)

TSF-5099
Temperature of minimum core loss (100°C)
Core loss at 100KHz, 1000 gauss (50 mw/cm³)

TSF-7099
Temperature of minimum core loss (100°C)
Core loss at 100KHz, 1000 gauss (70 mw/cm³)

TSF-7070
Temperature of minimum core loss (70°C)
Core loss at 100KHz, 1000 gauss (70 mw/cm³)

TSF-8040
Temperature of minimum core loss (40°C)
Core loss at 100KHz, 1000 gauss (80 mw/cm³)

TSF-5000
5,000 permeability

TSF-010K
10,000 permeability

E CORES TSF-5099-25-10-06-0000
Gap code (-0000 for ungapped)
Nominal thickness of core (F dimension) in rounded mm
Overall leg length of one core (B dimension) in rounded mm
Back length (A dimension) in rounded mm
Core material (TSF-5099)

POT CORES TSF-8040-14-08-00-0000
Gap code (-0000 for ungapped)
Nominal pair height (2 x B dimension) in rounded mm
Nominal outside diameter (A dimension) in rounded mm
Core material (TSF-8040)

TOROIDS TSF-5000-10-05-03-0000
Coating code (-0000 for uncoated)
Height of core (C dimension) in rounded mm
Inside diameter (B dimension) in rounded mm
Outside diameter (A dimension) in rounded mm
Core material (TSF-5000)

TSC Ferrite International

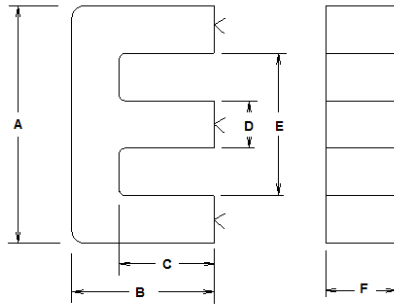

TSC FERRITE INTERNATIONAL E CORE DIMENSIONS

	PART #	A		B		C		D		E		F	
		in	mm	in	mm	in	mm	in	mm	in	mm	in	mm
	10-06-05	0.403 ±0.008	10.24 ±0.21	0.220 ±0.005	5.59 ±0.13	0.165 ±0.006	4.19 ±0.16	0.096 ±0.002	2.44 ±0.05	0.309 ±0.006	7.85 ±0.16	0.187 ±0.004	4.75 ±0.10
	12-08-04	0.485 ±0.010	12.32 ±0.25	0.305 ±0.005	7.75 ±0.13	0.220 ±0.007	5.59 ±0.17	0.105 ±0.002	2.67 ±0.05	0.315 ±0.006	8.00 ±0.16	0.170 ±0.003	4.32 ±0.09
	13-06-03	0.500 ±0.010	12.70 ±0.25	0.224 ±0.005	5.69 ±0.13	0.161 ±0.006	4.09 ±0.16	0.125 ±0.003	3.18 ±0.06	0.375 ±0.008	9.53 ±0.19	0.125 ±0.003	3.18 ±0.06
EF 12.6	13-06-04	0.500 ±0.010	12.70 ±0.25	0.252 ±0.005	6.40 ±0.13	0.183 ±0.006	4.65 ±0.16	0.144 ±0.003	3.66 ±0.07	0.356 ±0.007	9.04 ±0.18	0.142 ±0.003	3.61 ±0.07
	13-06-06	0.500 ±0.010	12.70 ±0.25	0.224 ±0.005	5.69 ±0.13	0.161 ±0.006	4.09 ±0.16	0.125 ±0.003	3.18 ±0.06	0.375 ±0.008	9.53 ±0.19	0.250 ±0.005	6.35 ±0.13
EE16	16-07-05	0.630 ±0.013	16.00 ±0.32	0.283 ±0.005	7.19 ±0.13	0.204 ±0.007	5.18 ±0.17	0.157 ±0.003	3.99 ±0.080	0.461 ±0.009	11.71 ±0.23	0.189 ±0.004	4.80 ±0.10
EF 16	16-08-05	0.634 ±0.013	16.10 ±0.32	0.317 ±0.005	8.05 ±0.13	0.232 ±0.007	5.89 ±0.17	0.179 ±0.004	4.55 ±0.09	0.460 ±0.009	11.68 ±0.23	0.177 ±0.004	4.50 ±0.09
	16-08-08	0.634 ±0.013	16.10 ±0.32	0.317 ±0.005	8.05 ±0.13	0.232 ±0.007	5.89 ±0.17	0.179 ±0.004	4.55 ±0.09	0.460 ±0.009	11.68 ±0.23	0.310 ±0.006	7.870 ±0.16
	19-07-05	0.750 ±0.015	19.05 ±0.38	0.299 ±0.005	7.60 ±0.13	0.206 ±0.007	5.230 ±0.17	0.187 ±0.004	4.75 ±0.10	0.564 ±0.011	14.33 ±0.29	0.187 ±0.004	4.75 ±0.10
E187 (3/16x3/16)	19-08-05	0.750 ±0.015	19.05 ±0.38	0.317 ±0.005	8.05 ±0.13	0.224 ±0.007	5.69 ±0.17	0.187 ±0.004	4.75 ±0.10	0.564 ±0.011	14.33 ±0.29	0.187 ±0.004	4.75 ±0.10
	19-08-09	0.750 ±0.015	19.05 ±0.38	0.317 ±0.005	8.05 ±0.13	0.224 ±0.007	5.69 ±0.17	0.187 ±0.004	4.75 ±0.10	0.564 ±0.011	14.33 ±0.29	0.343 ±0.007	8.71 ±0.17
EF 20	20-10-06	0.787 ±0.016	19.99 ±0.40	0.390 ±0.005	9.91 ±0.13	0.283 ±0.007	7.19 ±0.18	0.224 ±0.004	5.69 ±0.11	0.566 ±0.011	14.38 ±0.29	0.222 ±0.004	5.64 ±0.11
	20-10-10	0.787 ±0.016	19.99 ±0.40	0.390 ±0.005	9.91 ±0.13	0.283 ±0.007	7.19 ±0.18	0.224 ±0.004	5.69 ±0.11	0.566 ±0.011	14.38 ±0.29	0.346 ±0.007	8.790 ±0.18
E2425 (1/4x1/4)	25-10-06	1.000 ±0.020	25.40 ±0.51	0.380 ±0.005	9.65 ±0.13	0.260 ±0.007	6.60 ±0.19	0.250 ±0.005	6.35 ±0.13	0.757 ±0.015	19.23 ±0.39	0.250 ±0.005	6.35 ±0.13
E(1/4x1/2)	25-10-13	1.000 ±0.020	25.40 ±0.51	0.380 ±0.005	9.65 ±0.13	0.260 ±0.007	6.60 ±0.19	0.250 ±0.005	6.35 ±0.13	0.757 ±0.015	19.23 ±0.39	0.500 ±0.010	12.70 ±0.25
	25-12-06	1.000 ±0.020	25.40 ±0.51	0.470 ±0.005	11.94 ±0.13	0.350 ±0.007	8.89 ±0.19	0.250 ±0.005	6.35 ±0.13	0.757 ±0.015	19.23 ±0.39	0.250 ±0.005	6.35 ±0.13
EF 25	25-13-07	0.986 ±0.020	25.05 ±0.50	0.494 ±0.005	12.55 ±0.13	0.352 ±0.008	8.95 ±0.20	0.285 ±0.006	7.25 ±0.15	0.706 ±0.014	17.98 ±0.36	0.283 ±0.006	7.19 ±0.14
	25-13-10	0.986 ±0.020	25.05 ±0.50	0.494 ±0.005	12.55 ±0.13	0.352 ±0.008	8.95 ±0.20	0.285 ±0.006	7.25 ±0.15	0.706 ±0.014	17.98 ±0.36	0.423 ±0.008	10.74 ±0.22
EL2425	25-16-06	1.000 ±0.020	25.40 ±0.51	0.630 ±0.005	16.00 ±0.13	0.505 ±0.008	12.83 ±0.19	0.250 ±0.005	6.35 ±0.13	0.757 ±0.015	19.23 ±0.39	0.250 ±0.005	6.35 ±0.13
	25-16-13	1.000 ±0.020	25.40 ±0.51	0.630 ±0.005	16.00 ±0.13	0.505 ±0.008	12.83 ±0.19	0.250 ±0.005	6.35 ±0.13	0.757 ±0.015	19.23 ±0.39	0.500 ±0.010	12.70 ±0.25
	28-11-11	1.102 ±0.022	27.99 ±0.56	0.415 ±0.005	10.54 ±0.13	0.224 ±0.009	5.69 ±0.23	0.303 ±0.006	7.70 ±0.15	0.760 ±0.015	19.30 ±0.39	0.440 ±0.009	11.18 ±0.22

TSC Ferrite International

TSF FERRITE INTERNATIONAL E CORE EFFECTIVE CORE SET PARAMETERS							INDUCTANCE INDEX				
							AL nH/N ²				
							ASTM Material Type				
							ASTM P7099	ASTM P8040	ASTM F3000	ASTM P5099	ASTM P7070
							TSC Ferrite Material Grade				
							TSF-BOOST TSF-7099 TSF-5099 +25%	TSF-7070 +20%	TSF-8040 TSF-50ALL Flat Line +25%	TSF-5000 +25%	TSF-010K +30%
PART #	Le cm	Ae cm ²	Ve cm ³	Wa cm ²	WaAe cm ⁴	CORE SET WEIGHT GRAMS					
10-06-05	2.617	0.119	0.311	0.227	0.027	1.6	955	1,060	1,305	1,445	1,800
12-08-04	3.208	0.145	0.464	0.298	0.043	2.7	950	1,040	1,300	1,440	1,800
13-06-03	2.771	0.101	0.280	0.260	0.026	1.4	750	850	1,050	1,170	1,475
13-06-04	2.959	0.130	0.386	0.250	0.033	2.0	935	1,075	1,360	1,510	1,900
13-06-06	2.771	0.202	0.560	0.260	0.052	2.8	1,550	1,715	2,110	2,470	2,870
16-07-05	3.482	0.196	0.684	0.400	0.079	3.5	1,290	1,440	1,818	2,240	2,800
16-08-05	3.761	0.199	0.750	0.421	0.084	3.8	1,210	1,340	1,650	2,085	2,600
16-08-08	3.761	0.349	1.313	0.421	0.147	6.7	2,235	2,485	3,145	4,000	5,000
19-07-05	3.794	0.225	0.853	0.501	0.113	4.3	1,380	1,530	1,935	2,430	3,040
19-08-05	3.977	0.225	0.894	0.545	0.122	4.5	1,175	1,450	1,815	2,345	2,930
19-08-09	3.977	0.412	1.640	0.545	0.225	8.3	2,400	2,650	3,330	4,680	5,850
20-10-06	4.614	0.315	1.454	0.525	0.162	7.273	1,625	1,780	2,280	2,960	3,700
20-10-10	4.614	0.491	2.265	0.624	0.307	11.5	2,590	2,875	3,645	4,860	6,075
25-10-06	4.899	0.394	1.928	0.850	0.335	9.8	1,890	2,100	2,690	3,465	4,330
25-10-13	4.899	0.787	3.856	0.850	0.669	19.6	3,850	4,225	5,380	6,900	8,650
25-12-06	5.813	0.394	2.291	1.145	0.451	11.6	1,625	1,780	2,285	2,990	3,750
25-13-07	5.775	0.517	2.983	0.956	0.494	15.2	2,175	2,415	2,995	4,070	5,100
25-13-10	5.775	0.772	4.459	0.956	0.738	22.7	3,270	3,640	4,610	6,210	7,750
25-16-06	7.408	0.399	2.954	1.652	0.659	14.708	1,315	1,450	1,830	2,325	2,900
25-16-13	7.408	0.798	5.908	1.652	1.318	29.6	2,635	2,900	3,650	4,650	5,800
28-11-11	4.808	0.967	4.651	0.660	0.639	24.7	4,950	5,420	6,820	8,665	13,000

TSC Ferrite International

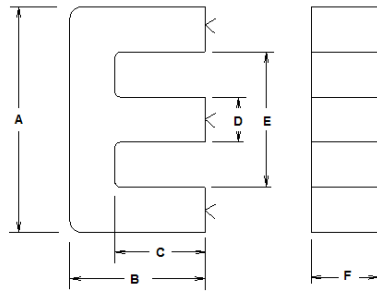

TSC FERRITE INTERNATIONAL E CORE DIMENSIONS

	PART #	A		B		C		D		E		F	
		in	mm	in	mm	in	mm	in	mm	in	mm	in	mm
	28-12-09	1.100 +/-0.022	27.94 +/-0.56	0.478 +/-0.005	12.14 +/-0.13	0.320 +/-0.008	8.13 +/-0.21	0.350 +/-0.007	8.89 +/-0.18	0.785 +/-0.016	19.94 +/-0.40	0.350 +/-0.007	8.89 +/-0.18
	30-13-08	1.185 +/-0.024	30.10 +/-0.60	0.517 +/-0.005	13.13 +/-0.13	0.320 +/-0.009	8.13 +/-0.23	0.421 +/-0.008	10.69 +/-0.21	0.801 +/-0.016	20.35 +/-0.41	0.320 +/-0.006	8.13 +/-0.16
EE 30/11mm	30-13-11	1.185 +/-0.024	30.10 +/-0.60	0.517 +/-0.005	13.13 +/-0.13	0.320 +/-0.009	8.13 +/-0.23	0.421 +/-0.008	10.69 +/-0.21	0.801 +/-0.016	20.35 +/-0.41	0.421 +/-0.008	10.69 +/-0.21
EE 30.5mm	30-14-09	1.200 +/-0.024	30.48 +/-0.61	0.526 +/-0.005	13.36 +/-0.13	0.356 +/-0.008	9.04 +/-0.21	0.363 +/-0.007	9.22 +/-0.18	0.878 +/-0.018	22.30 +/-0.45	0.363 +/-0.007	9.22 +/-0.18
EE 30/15mm	30-15-07	1.181 +/-0.024	30.00 +/-0.60	0.587 +/-0.005	14.91 +/-0.13	0.399 +/-0.009	10.13 +/-0.22	0.270 +/-0.005	6.86 +/-0.14	0.792 +/-0.016	20.12 +/-0.40	0.272 +/-0.005	6.91 +/-0.14
	30-17-07	1.181 +/-0.024	30.00 +/-0.60	0.678 +/-0.005	17.22 +/-0.13	0.490 +/-0.009	12.45 +/-0.22	0.270 +/-0.005	6.86 +/-0.14	0.792 +/-0.016	20.12 +/-0.40	0.272 +/-0.005	6.91 +/-0.14
EL 30/11 mm	30-21-11	1.181 +/-0.024	30.00 +/-0.60	0.837 +/-0.005	21.26 +/-0.13	0.640 +/-0.009	16.26 +/-0.23	0.421 +/-0.008	10.69 +/-0.21	0.787 +/-0.016	19.99 +/-0.40	0.421 +/-0.008	10.69 +/-0.21
EF 32	32-16-09	1.264 +/-0.025	32.11 +/-0.64	0.634 +/-0.005	16.10 +/-0.13	0.457 +/-0.009	11.61 +/-0.22	0.362 +/-0.007	9.19 +/-0.18	0.918 +/-0.018	23.32 +/-0.47	0.360 +/-0.007	9.15 +/-0.18
	32-16-11	1.264 +/-0.025	32.11 +/-0.64	0.634 +/-0.005	16.10 +/-0.13	0.457 +/-0.009	11.61 +/-0.22	0.362 +/-0.007	9.19 +/-0.18	0.918 +/-0.018	23.32 +/-0.47	0.419 +/-0.008	10.64 +/-0.21
	33-14-13	1.307 +/-0.026	33.20 +/-0.66	0.557 +/-0.005	14.15 +/-0.13	0.380 +/-0.009	9.65 +/-0.22	0.386 +/-0.008	9.80 +/-0.20	0.952 +/-0.019	24.18 +/-0.48	0.500 +/-0.010	12.70 +/-0.25
E375 (3/8x3/8)	34-14-09	1.351 +/-0.027	34.32 +/-0.69	0.556 +/-0.005	14.12 +/-0.13	0.385 +/-0.008	9.78 +/-0.21	0.367 +/-0.007	9.32 +/-0.19	1.025 +/-0.021	26.04 +/-0.52	0.367 +/-0.007	9.32 +/-0.19
E(3/8X1/2)	34-14-13	1.351 +/-0.027	34.32 +/-0.69	0.556 +/-0.005	14.12 +/-0.13	0.385 +/-0.008	9.78 +/-0.21	0.367 +/-0.007	9.32 +/-0.19	1.025 +/-0.021	26.04 +/-0.52	0.500 +/-0.010	12.70 +/-0.25
EF35	35-18-13	1.378 +/-0.028	35.00 +/-0.70	0.689 +/-0.005	17.50 +/-0.13	0.492 +/-0.009	12.50 +/-0.23	0.394 +/-0.008	10.00 +/-0.20	0.984 +/-0.020	24.99 +/-0.50	0.394 +/-0.008	10.00 +/-0.20
EL375	35-24-10	1.375 +/-0.028	34.93 +/-0.70	0.937 +/-0.005	23.80 +/-0.13	0.750 +/-0.009	19.05 +/-0.22	0.375 +/-0.008	9.53 +/-0.19	1.007 +/-0.020	25.58 +/-0.51	0.375 +/-0.008	9.53 +/-0.19
	36-19-09	1.400 +/-0.028	35.56 +/-0.71	0.750 +/-0.005	19.05 +/-0.13	0.515 +/-0.010	13.08 +/-0.25	0.490 +/-0.010	12.45 +/-0.25	0.950 +/-0.019	24.13 +/-0.48	0.367 +/-0.007	9.32 +/-0.19
EE40	40-17-11	1.575 +/-0.032	40.01 +/-0.80	0.669 +/-0.005	16.99 +/-0.13	0.404 +/-0.010	10.26 +/-0.26	0.421 +/-0.008	10.69 +/-0.21	1.103 +/-0.022	28.02 +/-0.56	0.421 +/-0.008	10.69 +/-0.21
E(1/2X1/4)	41-16-06	1.600 +/-0.032	40.64 +/-0.81	0.649 +/-0.005	16.48 +/-0.13	0.415 +/-0.010	10.54 +/-0.25	0.490 +/-0.010	12.45 +/-0.25	1.145 +/-0.023	29.08 +/-0.58	0.250 +/-0.005	6.35 +/-0.13
E21	41-16-12	1.600 +/-0.032	40.64 +/-0.81	0.649 +/-0.005	16.48 +/-0.13	0.415 +/-0.010	10.54 +/-0.25	0.490 +/-0.010	12.45 +/-0.25	1.145 +/-0.023	29.08 +/-0.58	0.490 +/-0.010	12.45 +/-0.25
E(1/2x1/2)	41-16-13	1.600 +/-0.032	40.64 +/-0.81	0.649 +/-0.005	16.48 +/-0.13	0.415 +/-0.010	10.54 +/-0.25	0.490 +/-0.010	12.45 +/-0.25	1.145 +/-0.023	29.08 +/-0.58	0.500 +/-0.010	12.70 +/-0.25
E 42/15mm	42-21-15	1.653 +/-0.033	41.99 +/-0.84	0.823 +/-0.005	20.90 +/-0.13	0.597 +/-0.010	15.16 +/-0.24	0.466 +/-0.009	11.84 +/-0.24	1.185 +/-0.024	30.10 +/-0.60	0.608 +/-0.012	15.44 +/-0.31
E 42/20mm	42-21-20	1.653 +/-0.033	41.99 +/-0.84	0.823 +/-0.005	20.90 +/-0.13	0.597 +/-0.010	15.16 +/-0.24	0.466 +/-0.009	11.84 +/-0.24	1.185 +/-0.024	30.10 +/-0.60	0.772 +/-0.015	19.61 +/-0.39

TSC Ferrite International

TSF FERRITE INTERNATIONAL E CORE EFFECTIVE CORE SET PARAMETERS							INDUCTANCE INDEX					
							AL nH/N ²					
							ASTM Material Type					
							ASTM P7099	ASTM P8040	ASTM F3000	ASTM P5099	ASTM P7070	P5025-100
							TSC Ferrite Material Grade					
							TSF-BOOST TSF-7099	TSF-8040 TSF-50ALL	TSF-5099 Flat Line	TSF-7070 +20%	TSF-5000 +25%	TSF-010K +30%
PART #	MAGNETIC PATH LENGTH Le cm	EFFECTIVE CORE AREA Ae cm ²	EFFECTIVE CORE VOLUME Ve cm ³	WINDOW AREA Wa cm ²	POWER HANDLING CAPABILITY INDEX WaAe cm ⁴	CORE SET WEIGHT GRAMS	TSF-BOOST TSF-7099	TSF-8040 TSF-50ALL	TSF-5099 Flat Line	TSF-7070 +20%	TSF-5000 +25%	TSF-010K +30%
28-12-09	5.638	0.736	4.151	0.898	0.661	21.4	3,200	3,555	4,502	5,750	8,500	
30-13-08	5.797	0.824	4.774	0.785	0.646	24.9	3,485	3,870	4,905	6,250	9,000	
30-13-11	5.797	1.083	6.281	0.785	0.850	32.7	4,500	4,975	6,440	8,050	12,000	
30-14-09	6.272	0.797	4.998	1.183	0.943	25.7	3,115	3,460	4,380	5,475	8,200	
30-15-07	6.607	0.573	3.785	1.344	0.770	20.752	2,105	2,330	2,940	4,035	6,000	
30-17-07	7.499	0.569	4.266	1.650	0.939	23.5	1,840	2,035	2,590	3,440	5,100	
30-21-11	9.022	1.098	9.904	1.511	1.659	50.3	2,990	3,260	4,125	5,675	8,500	
32-16-09	7.465	0.822	6.134	1.639	1.347	31.2	2,695	2,950	3,735	5,100	10,000	
32-16-11	7.465	0.956	7.139	1.639	1.567	36.3	3,145	3,495	4,425	5,970		
33-14-13	6.734	1.175	7.912	1.388	1.630	40.6	4,290	4,770	6,040	8,175	16,000	
34-14-09	6.942	0.813	5.646	1.634	1.329	28.9	2,870	3,230	4,050	5,450	10,000	
34-14-13	6.942	1.108	7.693	1.634	1.811	39.4	3,925	4,410	5,520	7,425	14,000	
35-18-13	8.069	1.002	8.082	1.873	1.876	41.1	3,045	3,385	4,285	5,780	11,000	
35-24-10	10.712	0.900	9.640	3.058	2.752	48.3	2,055	2,320	2,910	3,880	7,700	
36-19-09	8.266	1.110	9.176	1.528	1.697	47.2	3,300	3,670	4,645	6,275	12,000	
40-17-11	7.731	1.274	9.850	1.778	2.265	51.9	4,055	4,500	5,695	7,725	15,000	
41-16-06	7.750	0.758	5.878	1.754	1.330	30.3	2,390	2,705	3,380	4,515	8,000	
41-16-12	7.750	1.487	11.521	1.754	2.607	59.5	4,725	5,300	6,630	9,185	18,000	
41-16-13	7.750	1.517	11.754	1.754	2.660	60.7	4,825	5,400	6,755	9,360	18,360	
42-21-15	9.723	1.815	17.644	2.769	5.025	89.6	4,600	5,155	6,570	8,795	17,000	
42-21-20	9.723	2.304	22.404	2.769	6.381	113.8	5,845	6,555	8,340	11,165	22,000	

TSC Ferrite International

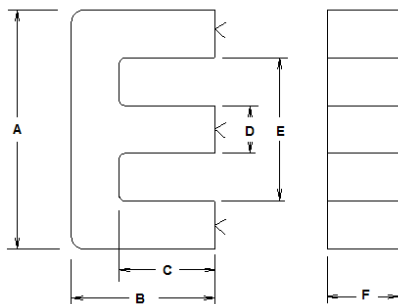

TSC FERRITE INTERNATIONAL E CORE DIMENSIONS

PART #	A		B		C		D		E		F	
	in	mm	in	mm	in	mm	in	mm	in	mm	in	mm
42-33-20	1.665	42.29	1.283	32.59	1.043	26.49	0.470	11.94	1.189	30.20	0.768	19.51
	+0.033	+0.85	+0.005	+0.13	+0.010	+0.25	+0.009	+0.24	+0.024	+0.60	+0.015	+0.39
43-21-15	1.687	42.85	0.831	21.11	0.596	15.14	0.468	11.89	1.219	30.96	0.608	15.44
	+0.034	+0.86	+0.005	+0.13	+0.010	+0.25	+0.009	+0.24	+0.024	+0.62	+0.012	+0.31
43-21-20	1.687	42.85	0.831	21.11	0.596	15.14	0.468	11.89	1.219	30.96	0.772	19.61
	+0.034	+0.86	+0.005	+0.13	+0.010	+0.25	+0.009	+0.24	+0.024	+0.62	+0.015	+0.39
43-21-22	1.687	42.85	0.831	21.11	0.596	15.14	0.468	11.89	1.219	30.96	0.875	22.23
	+0.034	+0.86	+0.005	+0.13	+0.010	+0.25	+0.009	+0.24	+0.024	+0.62	+0.018	+0.45
46-19-09	1.825	46.36	0.730	18.54	0.450	11.43	0.625	15.88	1.265	32.13	0.370	9.40
	+0.037	+0.93	+0.005	+0.13	+0.011	+0.27	+0.013	+0.32	+0.025	+0.64	+0.007	+0.19
E625 (5/8x5/8)	1.845	46.86	0.773	19.63	0.480	12.19	0.615	15.62	1.270	32.26	0.615	15.62
	+0.037	+0.94	+0.005	+0.13	+0.011	+0.28	+0.012	+0.31	+0.025	+0.65	+0.012	+0.31
47-21-32	1.845	46.86	0.773	19.63	0.480	12.19	0.615	15.62	1.270	32.26	1.230	31.24
	+0.037	+0.94	+0.005	+0.13	+0.011	+0.28	+0.012	+0.31	+0.025	+0.65	+0.025	+0.63
49-23-11	1.920	48.77	0.900	22.86	0.600	15.24	0.620	15.75	1.327	33.71	0.445	11.30
	+0.038	+0.98	+0.005	+0.13	+0.011	+0.28	+0.012	+0.32	+0.027	+0.67	+0.009	+0.23
E 55/21mm	2.170	55.12	1.083	27.51	0.740	18.80	0.667	16.94	1.500	38.10	0.815	20.70
	+0.043	+1.10	+0.005	+0.13	+0.012	+0.30	+0.013	+0.34	+0.030	+0.76	+0.016	+0.41
E 55/25mm	2.170	55.12	1.083	27.51	0.740	18.80	0.667	16.94	1.500	38.10	1.000	25.40
	+0.043	+1.10	+0.005	+0.13	+0.012	+0.30	+0.013	+0.34	+0.030	+0.76	+0.020	+0.51
55-28-31	2.170	55.12	1.083	27.51	0.740	18.80	0.667	16.94	1.500	38.10	1.218	30.94
	+0.043	+1.10	+0.005	+0.13	+0.012	+0.30	+0.013	+0.34	+0.030	+0.76	+0.024	+0.62
55-28-42	2.170	55.12	1.083	27.51	0.740	18.80	0.667	16.94	1.500	38.10	1.610	40.89
	+0.043	+1.10	+0.005	+0.13	+0.012	+0.30	+0.013	+0.34	+0.030	+0.76	+0.032	+0.82
E(3/4X3/4)	2.210	56.13	0.929	23.60	0.575	14.61	0.740	18.80	1.520	38.61	0.740	18.80
	+0.044	+1.12	+0.005	+0.13	+0.012	+0.31	+0.015	+0.38	+0.030	+0.77	+0.015	+0.38
59-25-19	2.312	58.72	0.972	24.69	0.575	14.61	0.724	18.39	1.518	38.56	0.735	18.67
	+0.046	+1.17	+0.005	+0.13	+0.013	+0.33	+0.014	+0.37	+0.030	+0.77	+0.015	+0.37
EE65	2.565	65.15	1.280	32.51	0.890	22.61	0.774	19.66	1.770	44.96	1.067	27.10
	+0.051	+1.30	+0.005	+0.13	+0.013	+0.33	+0.015	+0.38	+0.035	+0.89	+0.021	+0.53
70-54-32	2.750	69.85	2.125	53.98	1.687	42.85	0.875	22.23	1.876	47.65	1.250	31.75
	+0.055	+1.40	+0.005	+0.13	+0.014	+0.35	+0.018	+0.45	+0.038	+0.95	+0.025	+0.64
71-33-20	2.775	70.49	1.297	32.94	0.876	22.25	0.852	21.64	1.919	48.74	0.799	20.30
	+0.056	+1.41	+0.005	+0.13	+0.013	+0.34	+0.017	+0.43	+0.038	+0.98	0.016	+0.41
71-33-32	2.775	70.49	1.297	32.94	0.876	22.25	0.852	21.64	1.919	48.74	1.244	31.60
	+0.056	+1.41	+0.005	+0.13	+0.013	+0.34	+0.017	+0.43	+0.038	+0.98	0.025	+0.63
72-28-19	2.850	72.39	1.100	27.94	0.710	18.03	0.750	19.05	2.100	53.34	0.750	19.05
	+0.057	+1.45	+0.005	+0.13	+0.013	+0.33	+0.015	+0.38	+0.042	+1.07	+0.015	+0.38
EE80	3.150	80.01	1.500	38.10	1.110	28.19	0.780	19.81	2.370	60.20	0.780	19.81
	+0.063	+1.60	+0.005	+0.13	+0.013	+0.33	+0.016	+0.40	+0.047	+1.20	+0.016	+0.40

TSC Ferrite International

TSF FERRITE INTERNATIONAL E CORE EFFECTIVE CORE SET PARAMETERS							INDUCTANCE INDEX				
							AL nH/N ²				
							ASTM Material Type				
							ASTM P7099	ASTM P8040	ASTM F3000	ASTM F5000	ASTM F010K
							TSC Ferrite Material Grade				
							TSF-BOOST TSF-7099 TSF-5099 +25%	TSF-7070 +20%	TSF-8040 TSF-50ALL Flat Line +25%	TSF-5000 +25%	TSF-010K +30%
PART #	Le cm	Ae cm ²	Ve cm ³	Wa cm ²	WaAe cm ⁴	CORE SET WEIGHT GRAMS					
42-33-20	14.323	2.350	33.661	4.838	11.370	168.5	4,045	4,495	5,775	7,720	15,000
43-21-15	9.834	1.838	18.075	2.888	5.308	91.8	4,605	5,180	6,600	8,790	17,000
43-21-20	9.834	2.334	22.951	2.888	6.739	116.6	5,855	6,575	8,370	11,185	22,000
43-21-22	9.834	2.645	26.013	2.888	7.639	132.2	6,640	7,435	9,485	12,685	25,000
46-19-09	8.478	1.383	11.726	1.858	2.570	61.2	4,015	4,460	5,650	7,650	15,000
47-21-16	8.890	2.346	20.858	2.028	4.759	108.2	6,510	7,290	9,290	12,440	24,000
47-21-32	8.890	4.690	41.715	2.028	9.508	216.5	13,030	14,480	18,350	24,940	49,000
49-23-11	10.295	1.739	17.859	2.737	4.747	91.8	4,150	4,625	5,840	7,920	15,000
55-28-21	12.335	3.540	43.668	3.977	14.079	223.7	7,085	7,930	10,100	13,545	27,000
55-28-25	12.335	4.344	53.580	3.977	17.275	274.4	8,695	9,735	12,390	16,630	33,000
55-28-31	12.335	5.291	65.261	3.977	21.040	334.3	10,595	11,770	14,910	20,265	40,000
55-28-42	12.335	6.993	86.264	3.977	27.812	441.9	14,000	15,720	19,900	26,795	53,000
56-24-19	10.650	3.398	36.202	2.894	9.832	188.0	7,875	8,820	11,220	15,055	30,000
59-25-19	10.939	3.642	39.937	2.945	10.727	208.3	8,220	8,820	11,200	15,720	31,000
65-33-27	14.691	5.390	79.194	5.719	30.828	404.8	9,062	10,069	12,754	17,333	
70-54-32	23.175	7.055	163.488	10.895	76.858	822.2	7,520	8,275	10,580	14,380	
71-33-20	14.993	4.384	65.727	6.030	26.435	337.0	7,220	8,020	10,160	13,800	
71-33-32	14.993	6.825	102.337	6.030	41.158	524.7	11,245	12,495	15,825	21,510	
72-28-19	13.691	3.680	50.379	6.184	22.754	258.4	6,635	7,450	9,485	12,685	
80-38-20	18.428	3.925	72.334	11.386	44.693	365.5	5,260	5,880	7,110	10,050	

TSC Ferrite International

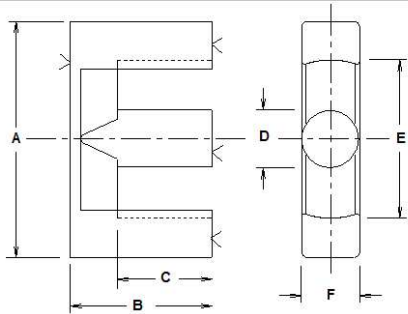

TSC FERRITE INTERNATIONAL ETD & EER CORE DIMENSIONS

PART #	A		B		C		D		E		F		
	in	mm	in	mm	in	mm	in	mm	in	mm	in	mm	
20-10-08	0.787 +/-0.016	19.99 +/-0.40	0.396 +/-0.005	10.06 +/-0.13	0.278 +/-0.007	7.06 +/-0.19	0.300 +/-0.006	7.62 +/-0.15	0.551 +/-0.011	14.00 +/-0.28	0.300 +/-0.006	7.62 +/-0.15	
20-13-08	0.787 +/-0.016	19.99 +/-0.40	0.527 +/-0.005	13.39 +/-0.13	0.409 +/-0.007	10.39 +/-0.19	0.300 +/-0.006	7.62 +/-0.15	0.551 +/-0.011	14.00 +/-0.28	0.300 +/-0.006	7.62 +/-0.15	
ETD29	29-00-00	1.178 +/-0.024	29.92 +/-0.61	0.622 +/-0.008	15.80 +/-0.20	0.432 +/-0.011	10.97 +/-0.28	0.374 +/-0.012	9.50 +/-0.30	0.890 +/-0.024	22.61 +/-0.61	0.374 +/-0.012	9.50 +/-0.30
EER28	29-14-11	1.124 +/-0.022	28.55 +/-0.57	0.551 +/-0.005	14.00 +/-0.13	0.380 +/-0.008	9.65 +/-0.21	0.390 +/-0.008	9.91 +/-0.20	0.852 +/-0.017	21.64 +/-0.43	0.449 +/-0.010	11.40 +/-0.25
EER28L	29-17-11	1.124 +/-0.022	28.55 +/-0.57	0.665 +/-0.005	16.89 +/-0.13	0.493 +/-0.008	12.52 +/-0.21	0.390 +/-0.008	9.91 +/-0.20	0.852 +/-0.017	21.64 +/-0.43	0.449 +/-0.010	11.40 +/-0.25
ETD34	34-00-00	1.347 +/-0.027	34.21 +/-0.69	0.681 +/-0.008	17.30 +/-0.20	0.476 +/-0.011	12.09 +/-0.28	0.425 +/-0.012	10.80 +/-0.30	1.036 +/-0.027	26.31 +/-0.69	0.425 +/-0.012	10.80 +/-0.30
EER35	35-21-11	1.378 +/-0.028	35.00 +/-0.70	0.835 +/-0.005	21.21 +/-0.13	0.610 +/-0.010	15.49 +/-0.24	0.445 +/-0.009	11.30 +/-0.23	1.039 +/-0.021	26.39 +/-0.53	0.445 +/-0.009	11.30 +/-0.23
ETD39	39-00-00	1.539 +/-0.031	39.09 +/-0.79	0.779 +/-0.008	19.79 +/-0.20	0.575 +/-0.015	14.61 +/-0.38	0.492 +/-0.012	12.50 +/-0.30	1.185 +/-0.031	30.10 +/-0.79	0.492 +/-0.012	12.50 +/-0.30
ETD44	44-00-00	1.732 +/-0.035	43.99 +/-0.89	0.878 +/-0.008	22.30 +/-0.20	0.650 +/-0.015	16.51 +/-0.38	0.583 +/-0.015	14.81 +/-0.38	1.311 +/-0.032	33.30 +/-0.81	0.583 +/-0.015	14.81 +/-0.38
ETD49	49-00-00	1.917 +/-0.043	48.69 +/-1.09	0.972 +/-0.008	24.69 +/-0.20	0.712 +/-0.016	18.08 +/-0.41	0.642 +/-0.015	16.31 +/-0.38	1.457 +/-0.035	37.01 +/-0.89	0.642 +/-0.015	16.31 +/-0.38
ETD59	59-00-00	2.355 +/-0.047	59.82 +/-1.20	1.221 +/-0.005	31.01 +/-0.13	0.886 +/-0.012	22.50 +/-0.30	0.853 +/-0.017	21.67 +/-0.43	1.760 +/-0.035	44.70 +/-0.89	0.863 +/-0.017	21.92 +/-0.44

TSC Ferrite International

							INDUCTANCE INDEX		
							AL nH/N ²		
							ASTM Material Type		
TSF FERRITE INTERNATIONAL ETD & EER CORE EFFECTIVE CORE SET PARAMETERS							ASTM P7099 ASTM P5099	ASTM P7070	ASTM P8040 ASTM F3000 P5025-100
PART #	MAGNETIC PATH LENGTH	EFFECTIVE CORE AREA	EFFECTIVE CORE VOLUME	WINDOW AREA	POWER HANDLING CAPABILITY INDEX	CORE SET WEIGHT	TSF-BOOST TSF-7099 TSF-5099	TSF-7070	TSF-8040 TSF-50ALL Flat Line
	Le cm	Ae cm ²	Ve cm ³	Wa cm ²	WaAe cm ⁴	GRAMS	+25%	+20%	+25%
20-10-08	4.484	0.456	2.047	0.444	0.203	11.4	2,470	2,750	3,475
20-13-08	5.856	0.456	2.673	0.662	0.302	14.8	1,880	2,090	2,650
29-00-00	7.200	0.760	5.50	1.438	1.093	15.0	2,580	2,850	3,610
29-14-11	6.355	0.867	5.567	1.133	0.992	35.1	3,380	3,760	4,760
29-17-11	7.494	0.867	6.495	1.469	1.273	41.1	2,835	3,150	3,985
34-00-00	7.976	0.973	7.770	1.876	1.826	39.7	2,310	3,210	4,070
35-21-11	9.381	1.044	9.793	2.338	2.440	55.5	2,730	3,034	3,842
39-00-00	9.350	1.249	11.702	2.571	3.211	58.5	3,170	3,520	4,460
44-00-00	10.475	1.732	18.112	3.053	5.288	90.8	3,250	4,360	5,520
49-00-00	11.562	2.114	24.467	3.744	7.914	122.4	4,340	4,825	6,110
59-00-00	14.212	3.545	50.382	5.185	18.379	283.0	6,160	6,840	8,665

TSC Ferrite International

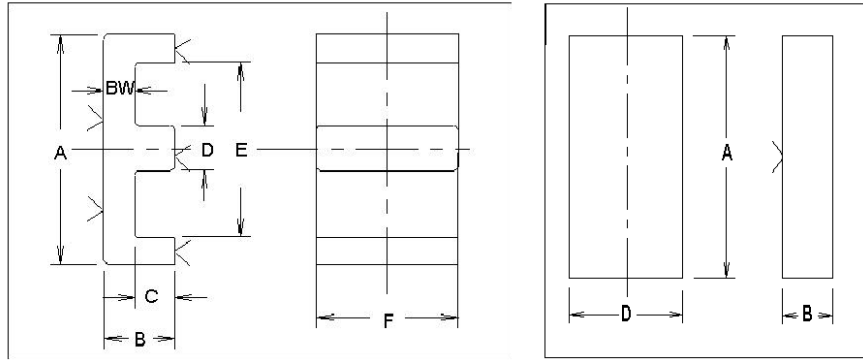

FIGURE 1

FIGURE 2

TSC FERRITE INTERNATIONAL PLANAR E CORE DIMENSIONS

PART #	Figure	A		B		C		D		E		F	
		in	mm	in	mm	in	mm	in	mm	in	mm	in	mm
14-02-05 I	#2	0.551 +-0.011	14.00 +-0.28	0.059 +-0.005	1.50 +-0.13			0.197 +-0.004	5.00 +-0.10				
14-04-05 E	#1	0.551 +-0.011	14.00 +-0.28	0.138 +-0.005	3.50 +-0.13	0.079 +-0.006	2.00 +-0.15	0.118 +-0.002	3.00 +-0.05	0.433 +-0.009	11.00 +-0.23	0.197 +-0.004	5.00 +-0.10
18-02-10 I	#2	0.709 +-0.014	18.00 +-0.36	0.079 +-0.005	2.00 +-0.13			0.394 +-0.008	10.00 +-0.20				
18-04-10 E	#1	0.709 +-0.014	18.00 +-0.36	0.157 +-0.005	3.99 +-0.13	0.078 +-0.007	1.98 +-0.18	0.157 +-0.003	3.99 +-0.07	0.551 +-0.011	14.00 +-0.28	0.394 +-0.008	10.00 +-0.20
22-03-17 I	#2	0.850 +-0.017	21.59 +-0.43	0.098 +-0.005	2.49 +-0.13			0.625 +-0.013	15.88 +-0.33				
22-06-17 E	#1	0.850 +-0.017	21.59 +-0.43	0.225 +-0.005	5.72 +-0.13	0.125 +-0.005	3.32 +-0.13	0.200 +-0.004	5.08 +-0.10	0.650 +-0.013	16.51 +-0.33	0.625 +-0.013	15.88 +-0.33
32-03-20 I	#2	1.252 +-0.025	31.80 +-0.64	0.126 +-0.005	3.20 +-0.13			0.800 +-0.016	20.32 +-0.41				
32-06-20 E	#1	1.252 +-0.025	31.80 +-0.64	0.250 +-0.005	6.35 +-0.13	0.125 +-0.008	3.18 +-0.20	0.250 +-0.005	6.35 +-0.13	1.000 +-0.020	25.40 +-0.51	0.800 +-0.016	20.32 +-0.41

PART #	TSC FERRITE INTERNATIONAL LP CORE EFFECTIVE CORE SET PARAMETERS						INDUCTANCE INDEX		
	MAGNETIC PATH LENGTH	EFFECTIVE CORE AREA	EFFECTIVE CORE VOLUME	WINDOW AREA	POWER HANDLING CAPABILITY INDEX	CORE SET WEIGHT	AL nH/N ²		
	Le cm	Ae cm ²	Ve cm ³	Wa cm ²	WaAe cm ⁴	GRAMS	ASTM Material Type		
							ASTM P7099 ASTM P5099	ASTM P7070	ASTM P8040 ASTM F3000 P5025-100
14-02-05 I	1.672	0.15	0.251	0.08	0.012	1.304	TSC Ferrite Material Grade TSF-BOOST TSF-7099 TSF-5099 +25%	TSF-8040 TSF-50ALL Flat Line +25%	TSF-7070 +25%
14-04-05 E	2.074	0.15	0.311	0.161	0.024	1.595	1,300	1,445	2,120
18-02-10 I	2.026	0.401	0.813	0.099	0.04	4.26	3,100	3,445	6,740
18-04-10 E	2.423	0.401	0.972	0.198	0.08	5.026	2,590	2,880	5,580
22-03-17 I	2.587	0.789	2.042	0.189	0.149	10.688	5,000	5,555	10,510
22-06-17 E	3.24	0.787	2.549	0.377	0.297	13.134	3,980	4,425	8,330
32-03-20 I	3.541	1.295	4.588	0.302	0.392	23.872	5,310	5,900	12,640
32-06-20 E	4.174	1.292	5.395	0.605	0.782	27.766	4,495	4,995	10,670

TSC Ferrite International

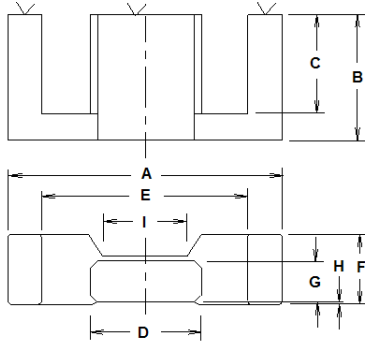

TSC FERRITE INTERNATIONAL EFD CORE DIMENSIONS

	PART #	A		B		C		D		E		F		G	
		in	mm	in	mm	in	mm	in	mm	in	mm	in	mm	in	mm
EFD15	15-08-05	0.591 ±0.012	15.00 ±0.30	0.292 ±0.005	7.42 ±0.13	0.217 ±0.007	5.50 ±0.17	0.209 ±0.004	5.30 ±0.11	0.433 ±0.009	11.00 ±0.22	0.182 ±0.004	4.62 ±0.09	0.093 ±0.002	2.36 ±0.05
EFD20	20-10-07	0.787 ±0.016	20.00 ±0.40	0.394 ±0.005	10.00 ±0.13	0.303 ±0.007	7.70 ±0.17	0.350 ±0.007	8.90 ±0.18	0.606 ±0.012	15.40 ±0.31	0.262 ±0.005	6.65 ±0.13	0.142 ±0.003	3.60 ±0.07
EFD25	25-13-09	0.984 ±0.020	25.00 ±0.50	0.492 ±0.005	12.50 ±0.13	0.366 ±0.008	9.30 ±0.19	0.449 ±0.009	11.40 ±0.23	0.736 ±0.015	18.70 ±0.37	0.358 ±0.007	9.10 ±0.18	0.205 ±0.004	5.20 ±0.10
EFD30	30-15-09	1.181 ±0.024	30.00 ±0.60	0.590 ±0.005	15.00 ±0.13	0.441 ±0.008	11.20 ±0.20	0.575 ±0.012	14.60 ±0.29	0.882 ±0.018	22.40 ±0.45	0.358 ±0.007	9.10 ±0.18	0.193 ±0.004	4.90 ±0.10

TSC FERRITE INTERNATIONAL EFD CORE EFFECTIVE CORE SET PARAMETERS							INDUCTANCE INDEX				
							AL nH/N ²				
PART #	MAGNETIC PATH LENGTH Le cm	EFFECTIVE CORE AREA Ae cm ²	EFFECTIVE CORE VOLUME Ve cm ³	WINDOW AREA Wa cm ²	POWER HANDLING CAPABILITY INDEX WaAe cm ⁴	CORE SET WEIGHT GRAMS	ASTM Material Type				
							ASTM P7099	ASTM P5099	ASTM P7070	ASTM P8040 ASTM F3000 P5025-100	ASTM F5000
							TSC Ferrite Material Grade				
							TSF-BOOST TSF-7099 TSF-5099 +/-25%	TSF-7070 +/-20%	TSF-8040 TSF-50ALL Flat Line +/-25%	TSF-5000 +/-30%	TSF-010K +/-30%
15-08-05	3.40	0.15	0.51	0.31	0.05	2.8	700	1,065	1,345	1,520	2,000
20-10-07	4.70	0.31	1.46	0.50	0.16	7.0	1,330	1,740	2,202	2,850	3,000
25-13-09	5.70	0.58	3.31	0.68	0.39	16.1	2,480	2,755	3,486		
30-15-09	6.80	0.69	4.70	0.87	0.60	24.0	2,470	2,745	3,475		

TSC Ferrite International

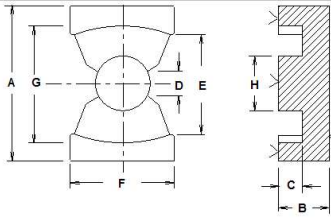

TSC FERRITE INTERNATIONAL PQ CORE DIMENSIONS

PART #	A		B		C		D		E		F		G		H		
	in	mm	in	mm	in	mm	in	mm	in	mm	in	mm	in	mm	in	mm	
PQ2016	20-16-00	0.837 +0.017	21.26 +0.43	0.319 +0.005	8.10 +0.13	0.203 +0.007	5.16 +0.19	0.158 MIN	4.01 MIN	0.472 MIN	11.99 MIN	0.551 +0.011	14.00 +-28	0.709 +0.016	18.01 +0.41	0.348 +0.007	8.84 +0.18
PQ2020	20-20-00	0.837 +0.017	21.26 +0.43	0.398 +0.005	10.11 +0.13	0.282 +0.007	7.16 +0.19	0.158 MIN	4.01 MIN	0.472 MIN	11.99 MIN	0.551 +0.011	14.00 +-28	0.709 +0.016	18.01 +0.41	0.348 +0.007	8.84 +0.18
PQ2620	26-20-00	1.073 +0.021	27.25 +0.55	0.397 +0.005	10.08 +0.13	0.226 +0.008	5.74 +0.21	0.236 MIN	5.99 MIN	0.610 MIN	15.49 MIN	0.748 +0.015	19.00 +-38	0.886 +0.018	22.50 +0.45	0.472 +0.009	11.99 +0.24
PQ2625	26-25-00	1.073 +0.021	27.25 +0.55	0.487 +0.005	12.37 +0.13	0.317 +0.008	8.05 +0.21	0.236 MIN	5.99 MIN	0.610 MIN	15.49 MIN	0.748 +0.015	19.00 +-38	0.886 +0.018	22.50 +0.45	0.472 +0.009	11.99 +0.24
PQ3220	32-20-00	1.300 +0.026	33.02 +0.66	0.405 +0.005	10.29 +0.13	0.226 +0.008	5.74 +0.22	0.216 MIN	5.49 MIN	0.748 MIN	19.00 MIN	0.866 +0.017	22.00 +-44	1.083 +0.022	27.51 +0.55	0.53 +0.011	13.46 +0.27
PQ3230	32-30-00	1.3 +0.026	33.02 +0.66	0.597 +0.005	15.16 +0.13	0.419 +0.009	10.64 +0.22	0.216 MIN	5.49 MIN	0.748 MIN	19.00 MIN	0.866 +0.017	22.00 +-44	1.083 +0.022	27.51 +0.55	0.53 +0.011	13.46 +0.27
PQ3535	35-35-00	1.422 +0.028	36.12 +0.72	0.684 +0.005	17.37 +0.13	0.492 +0.009	12.50 +0.22	0.235 MIN	5.97 MIN	0.925 MIN	23.50 MIN	1.024 +0.020	26.01 +-52	1.26 +0.025	32.00 +0.64	0.565 +0.011	14.35 +0.29
PQ4040	40-40-00	1.633 +0.033	41.48 +0.83	0.782 +0.005	19.86 +0.13	0.581 +0.009	14.76 +0.23	0.250 MIN	6.35 MIN	1.102 MIN	27.99 MIN	1.102 +0.022	27.99 +-56	1.457 +0.029	37.01 +0.74	0.587 +0.012	14.91 +0.30

TSC FERRITE INTERNATIONAL PQ CORE EFFECTIVE CORE SET PARAMETERS							INDUCTANCE INDEX		
							AL nH/N ²		
							ASTM Material Type		
							ASTM P7099	ASTM P7070	ASTM P8040 ASTM F3000 P5025-100
							TSC Ferrite Material Grade		
							TSF-BOOST TSF-7099	TSF-7070	TSF-8040 TSF-50ALL Flat Line
PART #	MAGNETIC PATH LENGTH Le cm	EFFECTIVE CORE AREA Ae cm ²	EFFECTIVE CORE VOLUME Ve cm ³	WINDOW AREA Wa cm ²	POWER HANDLING CAPABILITY INDEX WaAe cm ⁴	CORE SET WEIGHT GRAMS	TSF-5099 +-25%	TSF-7070 +-20%	TSF-8040 TSF-50ALL Flat Line +-25%
20-16-00	3.74	0.62	2.31	0.47	0.29	14.1	3,295	3,660	4,900
20-20-00	4.54	0.62	2.79	0.66	0.41	16.9	2,720	3,025	4,120
26-20-00	4.63	1.19	5.49	0.6	0.72	32.3	5,675	6,390	7,750
26-25-00	5.55	1.18	6.53	0.85	1	37.9	4,690	5,290	6,550
32-20-00	5.55	1.7	9.42	0.81	1.37	45.7	7,215	7,220	9,430
32-30-00	7.46	1.61	11.97	1.49	2.41	60.8	4,760	5,360	6,780
35-35-00	8.79	1.96	17.26	2.21	4.32	77.7	4,915	5,695	7,010
40-40-00	10.19	2.01	20.45	3.26	6.55	105.6	4,640	5,310	6,320

TSC Ferrite International

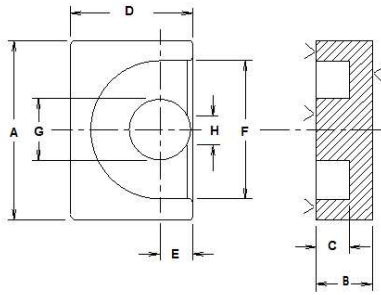

TSC FERRITE INTERNATIONAL EP CORE DIMENSIONS

PART #	A		B		C		D		E		F		G	
	in	mm	in	mm	in	mm	in	mm	in	mm	in	mm	in	mm
EP7 09-04-06	0.362 +/-0.007	9.20 +/-0.18	0.146 +/-0.003	3.71 +/-0.01	0.100 +/-0.002	2.54 +/-0.05	0.250 +/-0.005	6.35 +/-0.13	0.067 +/-0.004	1.70 +/-0.10	0.291 +/-0.008	7.39 +/-0.02	0.130 +/-0.004	3.30 +/-0.10
EP10 12-05-08	0.453 +/-0.012	11.50 +/-0.3	0.202 +/-0.004	5.13 +/-0.10	0.145 +/-0.003	3.68 +/-0.07	0.301 +/-0.008	7.60 +/-0.20	0.073 +/-0.004	1.85 +/-0.10	0.369 +/-0.007	9.37 +/-0.18	0.133 +/-0.003	3.38 +/-0.08
EP13 13-06-09	0.492 +/-0.011	12.50 +/-0.28	0.253 +/-0.005	6.43 +/-0.13	0.181 +/-0.004	4.60 +/-0.1	0.346 +/-0.008	8.79 +/-0.20	0.093 +/-0.005	2.36 +/-0.13	0.391 +/-0.008	9.93 +/-0.20	0.171 +/-0.003	4.34 +/-0.08
EP17 18-08-11	0.709 +/-0.014	18.00 +/-0.35	0.331 +/-0.003	8.41 +/-0.08	0.224 +/-0.004	5.69 +/-0.10	0.433 +/-0.009	11.00 +/-0.23	0.128 +/-0.003	3.25 +/-0.08	0.472 +/-0.009	11.99 +/-0.23	0.224 +/-0.004	5.69 +/-0.10

PART #	MAGNETIC PATH LENGTH Le cm	EFFECTIVE CORE AREA Ae cm^2	EFFECTIVE CORE VOLUME Ve cm^3	WINDOW AREA Wa cm^2	POWER HANDLING CAPABILITY INDEX WaAe cm^4	CORE SET WEIGHT GRAMS	INDUCTANCE INDEX AL nH/N^2				
							ASTM Material Type				
							ASTM P7099 ASTM P5099	ASTM P7070	ASTM P8040 ASTM F3000 P5025-100	ASTM F5000	ASTM F010K
							TSC Ferrite Material Grade				
						TSF-BOOST TSF-7099 TSF-5099 +/-25%	TSF-8040 TSF-50ALL TSF-7070 Flat Line +/-20%	TSF-8040 TSF-50ALL Flat Line +25%	TSF-5000 +/-30%	TSF-010K +/-30%	
09-04-06	1.57	0.10	0.16	0.04	0.00	1.4	1,100	1,120	1,240	2,575	5,140
12-05-08	1.92	0.11	0.22	0.09	0.01	2.8	1,060	1,080	1,200	2,315	4,611
13-06-09	2.42	0.20	0.47	0.15	0.03	5.1	1,565	1,590	2,000	3,170	6,313
18-08-11	2.85	0.34	0.97	0.24	0.08	11.6	2,400	2,655	3,100	4,679	9,319

TSC Ferrite International

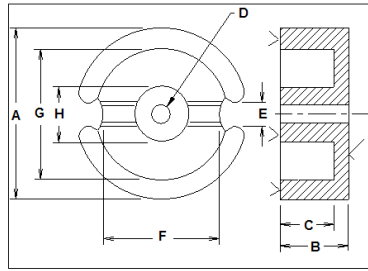

FIGURE 1

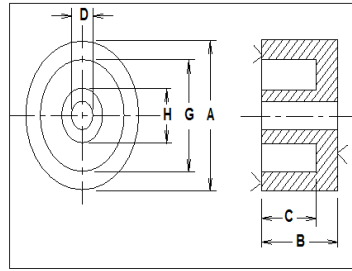

FIGURE 2

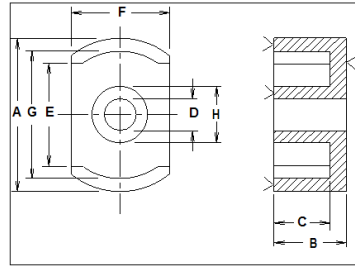

FIGURE 3

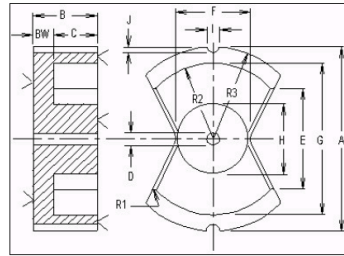

FIGURE 4

TSC FERRITE INTERNATIONAL POT CORE DIMENSIONS

PART #	Figure	A		B		C		D		E		F		G		H	
		in	mm	in	mm	in	mm	in	mm	in	mm	in	mm	in	mm	in	mm
14-08-00	#1	0.551	14.00	0.165	4.19	0.114	2.90	0.122	3.10	0.120	3.05	0.376	9.60	0.465	11.81	0.232	5.89
		+0.008	+0.20	+0.003	+0.08	+0.004	+0.10	+0.003	+0.07	MIN	MIN	NOM	NOM	+0.008	+0.20	+0.004	+0.10
14-09-08	#3	0.551	14.00	0.165	4.19	0.114	2.90	0.122	3.10	0.300	7.67	0.370	9.40	0.465	11.81	0.232	5.89
		+0.008	+0.20	+0.003	+0.08	+0.004	+0.10	+0.003	+0.07	MIN	MIN	+0.008	+0.20	+0.008	+0.20	+0.004	+0.10
18-11-00	#1	0.709	18.00	0.208	5.28	0.146	3.71	0.122	3.10	0.142	3.60	0.503	12.78	0.598	15.20	0.293	7.44
		+0.012	+0.30	+0.003	+0.08	+0.004	+0.10	+0.003	+0.08	MIN	MIN	NOM	NOM	+0.010	+0.25	+0.006	+0.15
18-11-11	#3	0.709	18.00	0.208	5.28	0.146	3.71	0.122	3.10	0.413	10.50	0.470	11.94	0.598	15.20	0.293	7.44
		+0.012	+0.30	+0.003	+0.08	+0.004	+0.10	+0.003	+0.08	MIN	MIN	+0.008	+0.20	+0.010	+0.25	+0.006	+0.15
22-13-00	#1	0.851	21.62	0.264	6.71	0.185	4.70	0.179	4.55	0.116	2.94	0.590	15.00	0.717	18.21	0.364	9.25
		+0.015	+0.38	+0.004	+0.10	+0.004	+0.10	+0.004	+0.10	MIN	MIN	NOM	NOM	+0.012	+0.30	+0.006	+0.15
23-11-00	#2	0.900	22.86	0.218	5.54	0.148	3.76	0.200	5.08					0.720	18.29	0.382	9.70
		+0.018	+0.46	+0.005	+0.13	+0.005	+0.13	+0.004	+0.10					+0.014	+0.36	+0.008	+0.20
23-13-11	#3	0.900	22.86	0.218	5.54	0.148	3.76	0.200	5.08	0.52	13.21	0.600	15.24	0.720	18.29	0.382	9.70
		+0.018	+0.46	+0.005	+0.13	+0.005	+0.13	+0.004	+0.10	MIN	MIN	+0.010	+0.25	+0.014	+0.36	+0.008	+0.20
23-18-00	#2	0.900	22.86	0.355	9.02	0.285	7.24	0.200	5.08					0.720	18.29	0.382	9.70
		+0.018	+0.46	+0.007	+0.18	+0.007	+0.18	+0.004	+0.10					+0.014	+0.36	+0.008	+0.20
23-13-18	#3	0.900	22.86	0.355	9.02	0.285	7.24	0.200	5.08	0.52	13.21	0.600	15.24	0.720	18.29	0.382	9.70
		+0.018	+0.46	+0.007	+0.18	+0.007	+0.18	+0.004	+0.10	MIN	MIN	+0.010	+0.25	+0.014	+0.36	+0.008	+0.20
26-16-00	#1	1.004	25.50	0.317	8.05	0.220	5.59	0.219	5.56	0.162	4.11	0.710	18.03	0.850	21.60	0.443	11.25
		+0.020	+0.51	+0.004	+0.10	+0.004	+0.10	+0.004	+0.10	MIN	MIN	NOM	NOM	+0.016	+0.41	+0.008	+0.20
30-19-00	#1	1.181	30.00	0.370	9.40	0.260	6.60	0.219	5.56	0.157	3.90	0.874	22.20	1.000	25.40	0.524	13.31
		+0.020	+0.50	+0.004	+0.10	+0.004	+0.10	+0.004	+0.10	MIN	MIN	NOM	NOM	+0.016	+0.41	+0.008	+0.20
36-22-00	#1	1.402	35.61	0.428	10.87	0.291	7.39	0.219	5.56	0.169	4.30	1.055	26.80	1.197	30.40	0.626	15.90
		+0.020	+0.51	+0.006	+0.15	+0.004	+0.10	+0.004	+0.10	MIN	MIN	NOM	NOM	+0.020	+0.51	+0.012	+0.30
62-49-00	#4	2.402	61.01	0.960	24.38	0.665	16.89	0.216	5.49	1.185	30.10	1.098	27.89	1.950	49.53	0.988	25.10
		+0.048	+1.22	+0.005	+0.13	+0.011	+0.28	+0.004	+0.10	+0.024	+0.61	+0.024	+0.61	+0.039	+0.99	+0.020	+0.51
74-59-00	#4	2.864	72.75	1.156	29.36	0.809	20.55	0.219	5.56	1.366	34.70	1.250	31.75	2.299	58.39	1.142	29.01
		+0.057	+1.45	+0.005	+0.13	+0.012	+0.30	+0.004	+0.10	+0.027	+0.69	+0.025	+0.64	+0.046	+1.17	+0.023	+0.58

TSC Ferrite International

							INDUCTANCE INDEX		
							AL		
							nH/N ²		
							ASTM Material Type		
							ASTM P7099	ASTM P7070	ASTM P8040
							ASTM P5099		P5025-100
TSC FERRITE INTERNATIONAL POT CORE EFFECTIVE CORE SET PARAMETERS							TSC Ferrite Material Grade		
	MAGNETIC PATH LENGTH	EFFECTIVE CORE AREA	EFFECTIVE CORE VOLUME	WINDOW AREA	POWER HANDLING CAPABILITY INDEX	CORE SET WEIGHT	TSF-BOOST TSF-7099		TSF-8040 TSF-50ALL
PART #	Le cm	Ae cm ²	Ve cm ³	Wa cm ²	WaAe cm ⁴	GRAMS	TSF-5099 +/-25%	TSF-7070 +/-20%	Flat Line +/-25%
14-08-00	1.98	0.25	0.50	0.17	0.04	3.3	2,100	2,350	2,540
14-09-08	2.25	0.22	0.50	0.17	0.04	2.5	1,625	1,820	1,965
18-11-00	2.59	0.43	1.11	0.29	0.12	7.1	3,125	3,440	4,120
18-11-11	2.72	0.41	1.11	0.29	0.12	6.0	2,840	3,120	3,740
22-13-00	3.13	0.64	2.00	0.42	0.27	13.3	3,805	4,230	5,050
23-11-00									
23-13-11	3.02	0.66	2.00	0.32	0.21	11.5	4,075	4,530	6,040
23-18-00									
23-13-18	4.24	0.66	2.75	0.62	0.41	16.5	2,900	3,220	4,300
26-16-00	3.77	0.93	3.50	0.58	0.54	22.3	5,670	6,300	6,795
30-19-00	4.52	1.36	6.15	0.80	1.09	36.9	6,915	7,685	9,190
36-22-00	5.21	1.99	10.34	1.07	2.13	61.8	8,785	9,760	11,660
62-49-00	10.9	5.7	62.0	4.1	23.5	280.0	8,280	9,200	11,040
74-59-00	12.8	7.9	101.0	6.4	50.6	460.0	9,000	10,000	12,000

TSC Ferrite International

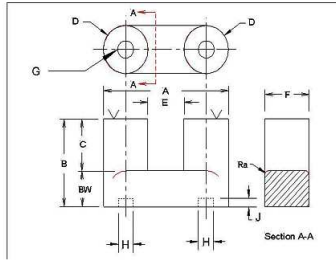

FIGURE 1

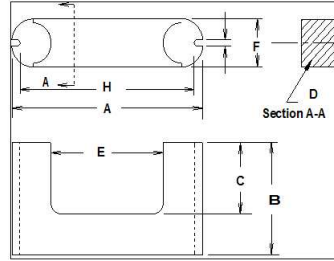

FIGURE 2

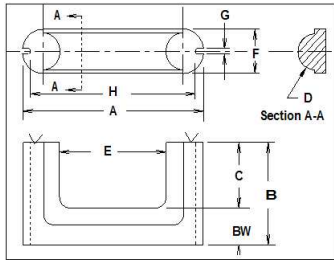

FIGURE 3

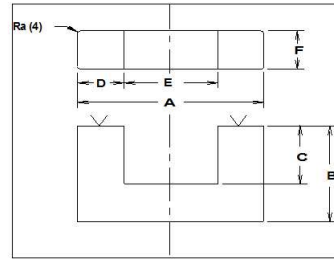

FIGURE 4

TSC FERRITE INTERNATIONAL U CORE DIMENSIONS

PART #	FIGURE	A		B		C		D		E		F		G		H	
		in	mm	in	mm	in	mm	in	mm	in	mm	in	mm	in	mm	in	mm
39-19-10	3	1.545 ±0.031	39.24 ±0.78	0.740 ±0.005	18.80 ±0.13	0.365 ±0.013	9.27 ±0.32	0.187 REF	4.75 REF	0.795 ±0.016	20.19 ±0.40	0.390 ±0.008	9.91 ±0.20	0.110 ±0.002	2.79 ±0.06	1.350 ±0.27	34.29 ±0.69
41-10-11	I Bar 2	1.620 ±0.032	41.15 ±0.82	0.388 ±0.005	9.86 ±0.13							0.460 ±0.009	11.68 ±0.23	0.125 ±0.003	3.18 ±0.06	1.390 REF	34.29 REF
41-21-11	2	1.620 ±0.032	41.15 ±0.82	0.812 ±0.005	20.62 ±0.13	0.437 ±0.013	11.10 ±0.32	0.230 REF	5.84 REF	0.750 ±0.015	19.05 ±0.38	0.460 ±0.009	11.68 ±0.23	0.125 ±0.003	3.18 ±0.06	1.390 REF	34.29 REF
41-22-11	2	1.620 ±0.032	41.15 ±0.82	0.875 ±0.005	22.23 ±0.13	0.500 ±0.013	12.70 ±0.32	0.230 REF	5.84 REF	0.750 ±0.015	19.05 ±0.38	0.460 ±0.009	11.68 ±0.23	0.125 ±0.003	3.18 ±0.06	1.390 REF	34.29 REF
41-25-11	2	1.620 ±0.032	41.15 ±0.82	1.000 ±0.005	25.40 ±0.13	0.625 ±0.013	15.88 ±0.32	0.230 REF	5.84 REF	0.750 ±0.015	19.05 ±0.38	0.460 ±0.009	11.68 ±0.23	0.125 ±0.003	3.18 ±0.06	1.390 REF	34.29 REF
41-30-11	2	1.620 ±0.032	41.15 ±0.82	1.200 ±0.015	30.48 ±0.38	0.825 ±0.013	20.96 ±0.32	0.230 REF	5.84 REF	0.750 ±0.015	19.05 ±0.38	0.460 ±0.009	11.68 ±0.23	0.125 ±0.003	3.18 ±0.06	1.390 REF	34.29 REF
64-40-24	U64 1	2.521 ±0.050	64.03 ±1.27	1.594 ±0.005	40.49 ±0.13	1.043 ±0.016	26.49 ±0.41	0.789 ±0.106	20.04 ±2.69	0.945 ±0.019	24.00 ±0.48	0.945 ±0.019	24.00 ±0.48	0.165 ±0.003	4.19 ±0.08	0.378 ±0.008	9.60 ±0.20
69-24-14	3	2.726 ±0.055	69.24 ±1.40	0.953 ±0.005	24.20 ±0.13	0.500 ±0.014	12.70 ±0.36	0.257 ±0.005	6.53 ±0.13	1.705 ±0.34	43.31 ±8.64	0.545 ±0.011	13.84 ±0.28	0.140 ±0.003	3.56 ±0.08	2.483 ±0.050	63.07 ±1.27
81-13-16	I Bar 3	3.205 ±0.064	81.36 ±1.63	0.500 ±0.005	12.70 ±0.13							0.625 ±0.013	15.88 ±0.32	0.140 ±0.003	3.56 ±0.07	2.990 ±0.060	75.95 ±1.52
81-33-16	3	3.205 ±0.064	81.36 ±1.63	1.285 ±0.005	32.64 ±0.13	0.750 ±0.010	19.05 ±0.25	0.312 REF	7.92 REF	2.000 ±0.030	50.80 ±0.76	0.625 ±0.013	15.88 ±0.32	0.140 ±0.003	3.56 ±0.07	2.990 ±0.060	75.95 ±1.52
93-28-16	I Bar 4	3.661 ±0.073	92.99 ±1.85	1.102 ±0.005	27.99 ±0.13							0.630 ±0.052	16.00 ±32				
93-76-16	4	3.661 ±0.073	92.99 ±1.85	2.992 ±0.005	76.00 ±0.13	1.890 ±0.27	48.01 ±0.69	1.102 -0.022	27.99 ±0.56	1.457 ±0.029	37.01 ±0.74	0.630 ±0.052	16.00 ±32				
93-28-30	I Bar 4	3.661 ±0.073	92.99 ±1.85	1.102 ±0.005	27.99 ±0.13							1.181 ±0.024	30.00 ±56				
93-76-30	4	3.661 ±0.073	92.99 ±1.85	2.992 ±0.005	76.00 ±0.13	1.890 ±0.27	48.01 ±0.69	1.102 -0.022	27.99 ±0.56	1.457 ±0.029	37.01 ±0.74	1.181 ±0.024	30.00 ±56				
102-25-25	I Bar 4	4.000 ±0.080	101.60 ±2.03	1.000 ±0.005	25.40 ±0.13							1.000 ±0.020	25.40 ±0.51				
102-57-25	4	4.000 ±0.080	101.60 ±2.03	2.250 ±0.005	57.15 ±0.13	1.250 ±0.025	31.75 ±0.64	1.000 ±0.020	25.40 ±0.51	2.000 ±0.040	50.80 ±1.02	1.000 ±0.020	25.40 ±0.51				

TSC Ferrite International

							INDUCTANCE INDEX AL nH/N ²	
							ASTM Material Type	
							ASTM P7099	ASTM P7070
							ASTM P5099	
TSC FERRITE INTERNATIONAL U CORE EFFECTIVE CORE SET PARAMETERS							TSC Ferrite Material Grade	
	MAGNETIC PATH LENGTH	EFFECTIVE CORE AREA	EFFECTIVE CORE VOLUME	WINDOW AREA	POWER HANDLING CAPABILITY INDEX	CORE SET WEIGHT	TSF-BOOST TSF-7099 TSF-5099	TSF-7070
PART #	Le cm	Ae cm ²	Ve cm ³	Wa cm ²	WaAe cm ⁴	GRAMS	+25%	+25%
39-19-10	10.79	0.78	8.42	3.74	2.92	44.60	1,796	1,995
41-10-11								
41-21-11	12.21	1.00	12.21	4.23	4.23	62.2	2,047	2,265
41-22-11	12.85	1.00	12.85	4.84	4.84	67.45	2,039	2,266
41-25-11	13.48	1.00	13.48	6.05	6.05	80.9	1,845	2,050
41-30-11	15.51	1.00	15.51	7.98	7.98	124.1	1,620	1,800
64-40-24	20.68	3.20	66.12	12.72	40.70	355	2,100	2,325
69-24-14	22.41	1.89	42.41	11.00	20.79	209.8	2,332	2,100
81-13-16								
81-33-16	22.41	1.91	42.80	19.35	36.97	259.06	2,099	2,332
93-28-16								
93-76-16	35.40	4.48	158.55	35.53	159.15	817.77	3,122	3,469
93-28-30								
93-76-30	35.40	8.40	297.22	35.53	298.34	1533	5,860	6,510
102-25-25								
102-57-25	25.76	6.45	166.15	32.26	208.06	1028.94	6,183	6,870

TSC Ferrite International

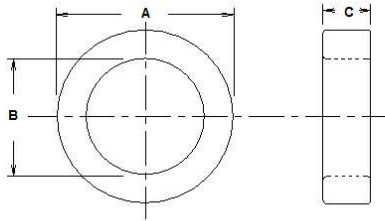

TSC FERRITE INTERNATIONAL TOROID DIMEN

PART #	A		B		C	
	in	mm	in	mm	in	mm
10-05-03	0.375	9.53	0.187	4.75	0.125	3.18
	+/-0.010	+/-0.25	+/-0.005	+/-0.13	+/-0.005	+/-0.13
10-05-06	0.375	9.53	0.187	4.75	0.250	6.35
	+/-0.010	+/-0.25	+/-0.005	+/-0.13	+/-0.005	+/-0.13
13-07-05	0.500	12.70	0.281	7.14	0.188	4.78
	+/-0.010	+/-0.25	+/-0.010	+/-0.25	+/-0.005	+/-0.13
13-07-06	0.500	12.70	0.281	7.14	0.250	6.35
	+/-0.010	+/-0.25	+/-0.010	+/-0.25	+/-0.010	+/-0.25
13-08-03	0.500	12.70	0.312	7.92	0.125	3.18
	+/-0.010	+/-0.25	+/-0.010	+/-0.25	+/-0.005	+/-0.13
13-08-06	0.500	12.70	0.312	7.92	0.250	6.35
	+/-0.010	+/-0.25	+/-0.010	+/-0.25	+/-0.010	+/-0.25
16-09-05	0.625	15.88	0.357	9.07	0.185	4.70
	+/-0.012	+/-0.25	+/-0.010	+/-0.25	+/-0.005	+/-0.13
16-09-10	0.625	15.88	0.357	9.07	0.375	9.53
	+/-0.012	+/-0.30	+/-0.010	+/-0.25	+/-0.010	+/-0.25
22-14-06	0.870	22.10	0.540	13.72	0.250	6.35
	+/-0.017	+/-0.43	+/-0.012	+/-0.30	+/-0.010	+/-0.25
22-14-07	0.870	22.10	0.540	13.72	0.275	6.99
	+/-0.017	+/-0.43	+/-0.012	+/-0.30	+/-0.010	+/-0.25
22-14-13	0.870	22.10	0.540	13.72	0.500	12.70
	+/-0.017	+/-0.43	+/-0.012	+/-0.30	+/-0.010	+/-0.25
25-16-08	1.000	25.40	0.610	15.49	0.312	7.92
	+/-0.020	+/-0.51	+/-0.015	+/-0.38	+/-0.010	+/-0.25
29-19-08	1.142	29.01	0.748	19.00	0.300	7.62
	+/-0.025	+/-0.61	+/-0.016	+/-0.41	+/-0.010	+/-0.25
29-19-15	1.142	29.01	0.748	19.00	0.600	15.24
	+/-0.025	+/-0.61	+/-0.016	+/-0.41	+/-0.010	+/-0.25
32-19-06	1.250	31.75	0.740	18.80	0.250	6.35
	+/-0.025	+/-0.64	+/-0.148	+/-0.38	+/-0.005	+/-0.13
32-19-11	1.250	31.75	0.740	18.80	0.435	11.05
	+/-0.025	+/-0.64	+/-0.148	+/-0.38	+/-0.009	+/-0.23
36-23-15	1.432	36.37	0.890	22.61	0.605	15.37
	+/-0.025	+/-0.61	+/-0.020	+/-0.51	+/-0.010	+/-0.25
37-30-16	1.469	37.31	1.168	29.67	0.625	15.88
	+/-0.029	+/-0.75	+/-0.023	+/-0.59	+/-0.013	+/-0.33
38-19-25	1.500	38.10	0.750	19.05	1.000	25.40
	+/-0.030	+/-0.76	+/-0.015	+/-0.38	+/-0.020	+/-0.51
40-24-16	1.574	39.98	0.944	23.98	0.629	15.98
	+/-0.032	+/-0.81	+/-0.019	+/-0.48	+/-0.013	+/-0.33
49-34-16	1.932	49.07	1.332	33.83	0.625	15.88
	+/-0.039	+/-0.99	+/-0.027	+/-0.69	+/-0.013	+/-0.33
51-32-19	2.000	50.80	1.250	31.75	0.750	19.05
	+/-0.040	+/-1.02	+/-0.025	+/-0.64	+/-0.015	+/-0.38

TSC Ferrite International

DIMENSIONS	TSC FERRITE INTERNATIONAL TOROIDAL CORE EFFECTIVE PARAMETERS						INDUCTANCE INDEX				
							AL nH/N ²				
	MAGNETIC PATH LENGTH	EFFECTIVE CORE AREA	EFFECTIVE CORE VOLUME	WINDOW AREA	POWER HANDLING CAPABILITY INDEX	CORE WEIGHT	ASTM Material Type				
							ASTM P7099 ASTM P5099	ASTM P7070	ASTM P8040 ASTM F3000 P5025-100	ASTM F5000	ASTM F010K
PART #	Le cm	Ae cm ²	Ve cm ³	Wa cm ²	WaAe cm ⁴	GRAMS	TSC Ferrite Material Grade				
							TSF-BOOST TSF-7099 TSF-5099 +30%	TSF-7070 +25%	TSF-8040 TSF-50ALL Flat Line +25%	TSF-5000 +25%	TSF-010K +30%
10-05-03	2.07	0.07	0.15	0.18	0.01	0.8	885	972	1,370	2,209	4,390
10-05-06	2.07	0.15	0.30	0.18	0.03	1.6	1,765	1,944	2,740	4,419	6,615
13-07-05	2.95	0.13	0.38	0.40	0.05	2.0	1,100	1,210	1,706	2,752	5,430
13-07-06	2.95	0.17	0.51	0.40	0.07	2.6	1,465	1,610	2,269	3,659	7,225
13-08-03	3.12	0.07	0.23	0.49	0.04	1.2	600	659	928	1,497	2,975
13-08-06	3.13	0.15	0.47	0.49	0.07	2.4	1,200	1,318	1,857	2,995	5,935
16-09-05	3.72	0.16	0.58	0.65	0.10	3.0	1,050	1,158	1,632	2,632	5,520
16-09-10	3.72	0.32	1.18	0.65	0.20	6.1	2,130	2,347	3,307	5,334	11,040
22-14-06	5.42	0.26	1.42	1.48	0.39	7.2	1,210	1,333	1,878	3,029	6,040
22-14-07	5.42	0.29	1.56	1.48	0.42	7.9	1,330	1,466	2,065	3,331	6,645
22-14-13	5.42	0.52	2.83	1.48	0.77	14.4	2,420	2,665	3,755	6,057	12,080
25-16-08	6.17	0.39	2.37	1.89	0.73	12.1	1,565	1,724	2,429	3,917	7,825
29-19-08	7.32	0.38	2.75	2.84	1.07	13.8	1,290	1,419	1,999	3,224	6,340
29-19-15	7.32	0.75	5.50	2.84	2.13	27.8	2,580	2,837	3,998	6,447	12,895
32-19-06	7.59	0.40	3.05	2.78	1.12	15.7	1,330	1,465	2,064	3,329	6,105
32-19-11	7.59	0.70	5.31	2.78	1.84	27.3	2,315	2,549	3,591	5,793	11,580
36-23-15	8.92	1.04	9.26	4.01	4.17	47.0	2,925	3,216	4,531	7,309	13,400
37-30-16	10.43	0.60	6.30	6.91	4.18	30.6	1,455	1,602	2,257	3,640	7,280
38-19-25	8.30	2.32	19.29	2.85	6.61	104.9	7,045	7,750	10,915	17,600	35,210
40-24-16	9.62	1.25	12.04	4.52	5.65	61.6	3,270	3,595	5,064	8,168	16,330
49-34-16	12.73	1.20	15.22	8.99	10.79	75.6	2,365	2,600	3,660	5,900	11,805
51-32-19	12.50	1.78	22.27	7.92	14.10	112.9	3,580	3,940	5,551	8,954	17,900

TSC Ferrite International

Custom Cores

We design and fabricate our own carbide tooling to produce custom core sizes and shapes. We also make small quantities of custom cores for prototypes by machining a block of pressed ferrite material before it is sintered. These samples are machined oversize per the material shrinkage that will take place when they are sintered. Samples produced this way have the same characteristics as they would if they were molded in production (same dimensional tolerances, material permeability, core losses, etc.).

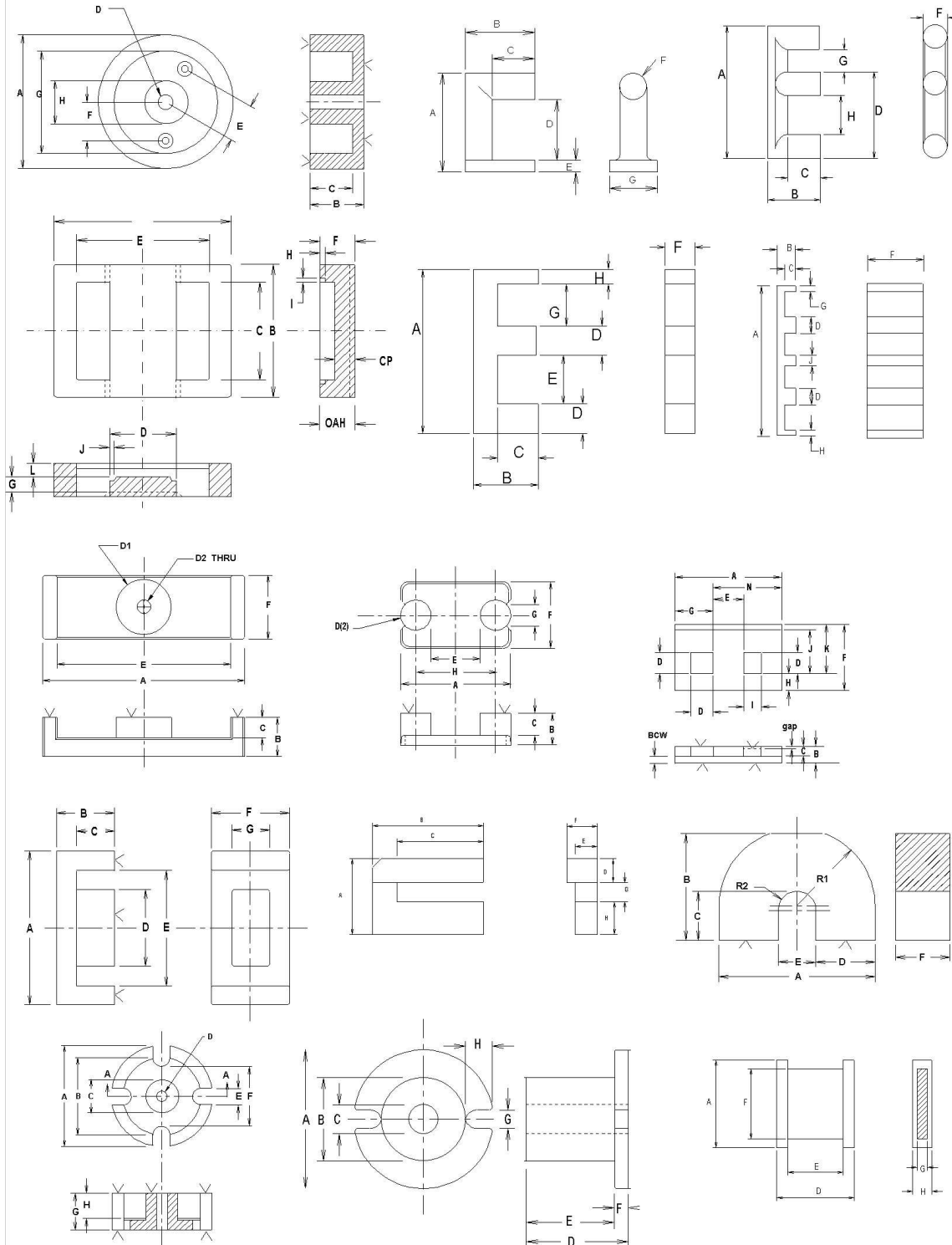

TSC Ferrite International

Custom Cores

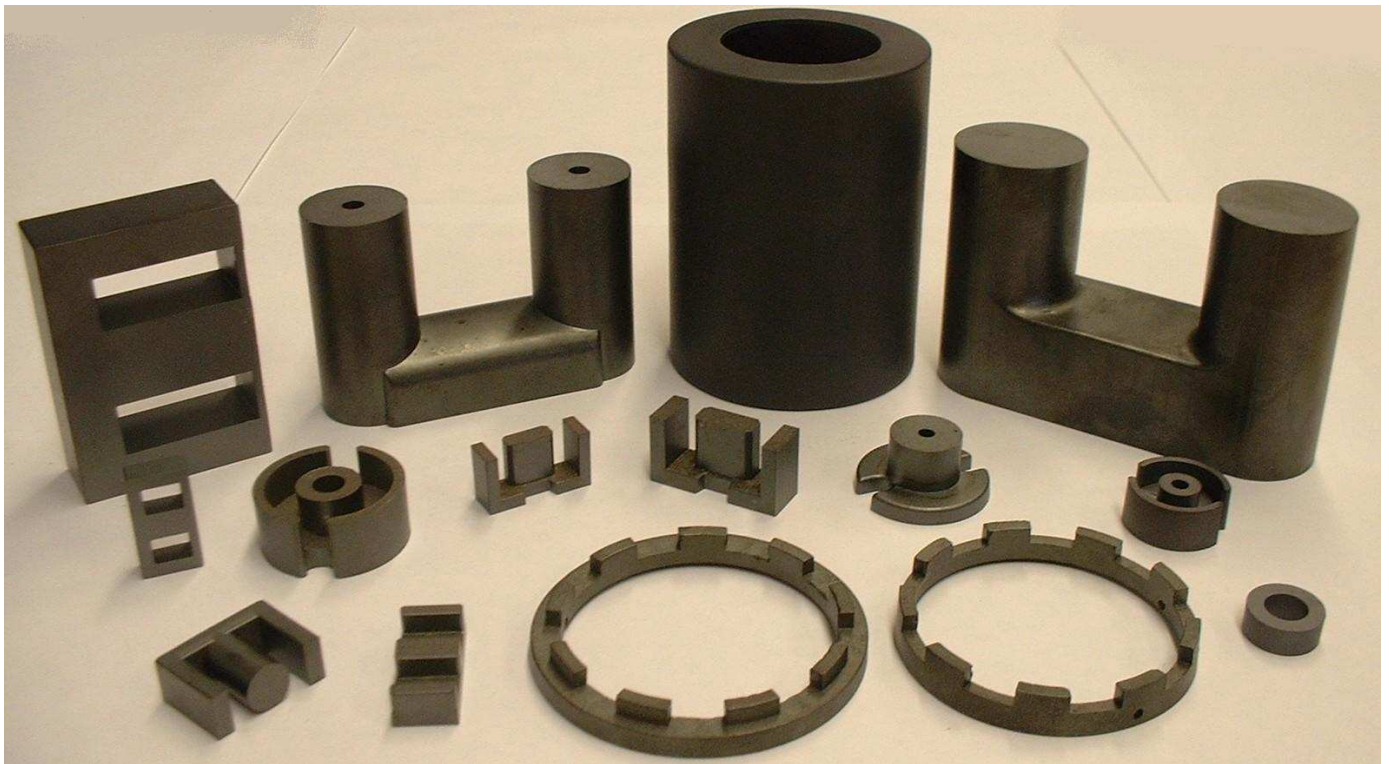
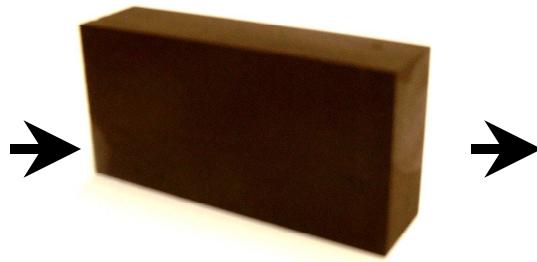
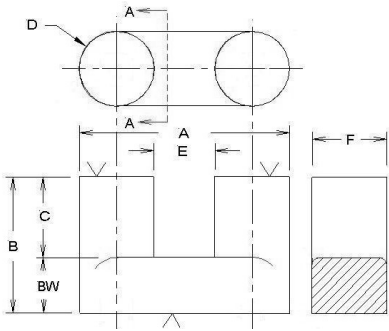

TSC Ferrite International

IRON POWDER / SOFT FERRITE COMPOSITE E CORES

TSC combines the low core loss of soft ferrite with the inherent distributed air gap of iron powder cores resulting in an E core set that has relatively high effective permeability. The permeability rolls off only minimally under large amounts of magnetizing force and supports large magnitudes of magnetizing force without saturating. The distributed air gap keeps the flux from fringing and the high resistivity of soft ferrite results in low core losses.

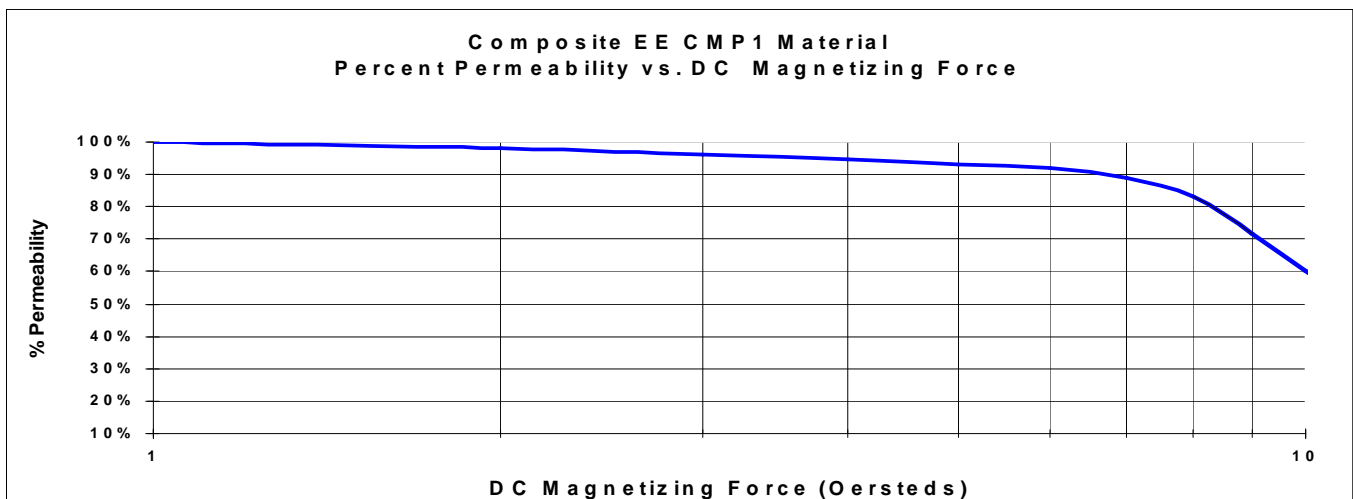
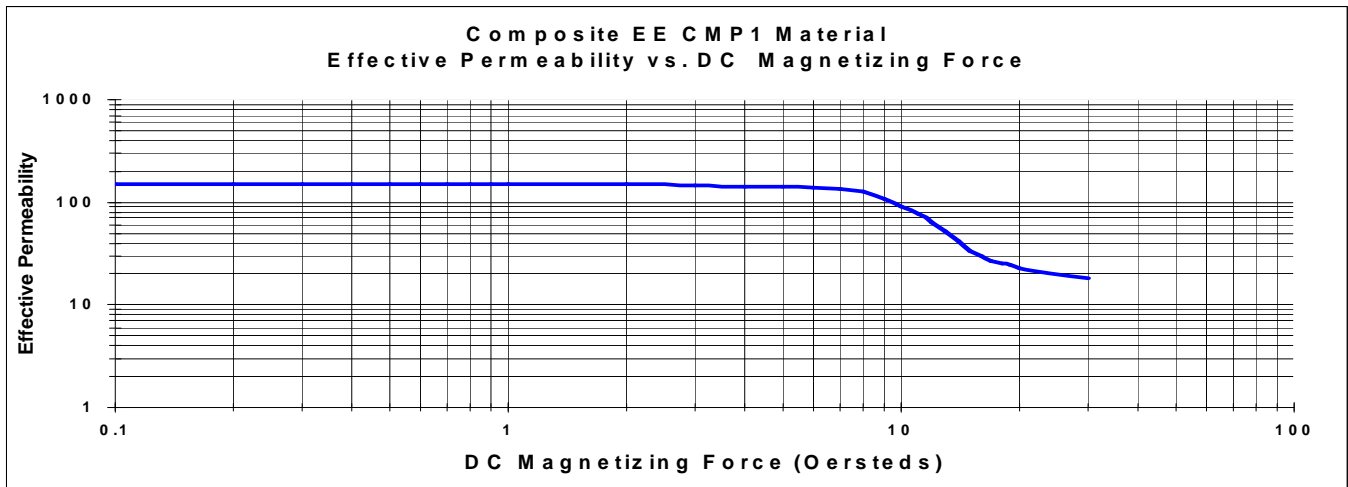
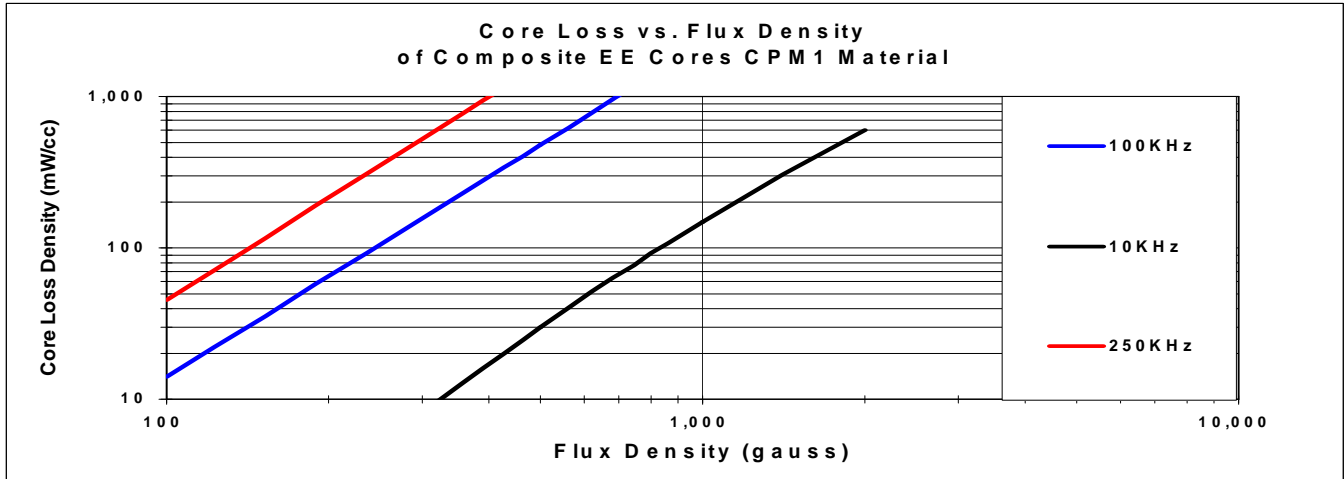

TSC Ferrite International

IRON POWDER / SOFT FERRITE COMPOSITE E CORES

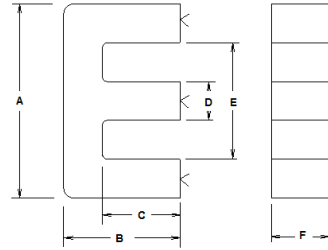

TSC FERRITE INTERNATIONAL COMPOSITE E CORE DIMENSIONS

	PART #	A		B		C		D		E		F	
		in	mm	in	mm	in	mm	in	mm	in	mm	in	mm
EF 12.6	13-06-04-0051	0.500 +/-0.012	12.70 +/-0.30	0.252 +/-0.005	6.40 +/-0.13	0.183 +/-0.006	4.65 +/-0.15	0.144 +/-0.009	3.66 +/-0.23	0.356 +/-0.019	9.04 +/-0.48	0.142 +/-0.008	3.61 +/-0.20
EF 16	16-08-05-0063	0.634 +/-0.013	16.10 +/-0.61	0.317 +/-0.006	8.05 +/-0.15	0.232 +/-0.008	5.89 +/-0.20	0.179 +/-0.008	4.55 +/-0.20	0.460 +/-0.009	11.68 +/-0.23	0.177 +/-0.008	4.50 +/-0.20
E187	19-08-05-0075	0.750 +/-0.015	19.05 +/-0.38	0.317 +/-0.006	8.05 +/-0.15	0.224 +/-0.006	5.69 +/-0.15	0.187 +/-0.007	4.75 +/-0.18	0.564 +/-0.012	14.33 +/-0.30	0.187 +/-0.007	4.75 +/-0.18
EF 20	20-10-06-0080	0.787 +/-0.018	19.99 +/-0.46	0.390 +/-0.007	9.91 +/-0.17	0.283 +/-0.013	7.19 +/-0.33	0.224 +/-0.013	5.69 +/-0.33	0.566 +/-0.016	14.38 +/-0.41	0.222 +/-0.013	5.64 +/-0.33
E2425	25-10-06-0100	1.000 +/-0.020	25.40 +/-0.51	0.380 +/-0.010	9.65 +/-0.25	0.260 +/-0.015	6.60 +/-0.38	0.250 +/-0.007	6.35 +/-0.18	0.757 +/-0.015	19.23 +/-0.38	0.250 +/-0.009	6.35 +/-0.23
EF25	25-13-07-0099	0.986 +/-0.020	25.05 +/-0.50	0.494 +/-0.005	12.55 +/-0.13	0.352 +/-0.008	8.95 +/-0.20	0.285 +/-0.006	7.25 +/-0.15	0.706 +/-0.014	17.98 +/-0.36	0.283 +/-0.006	7.19 +/-0.14
EE 30/15mm	30-15-07-0118	1.181 +/-0.024	30.00 +/-0.61	0.587 +/-0.011	14.91 +/-0.28	0.399 +/-0.013	10.13 +/-0.33	0.270 +/-0.015	6.86 +/-0.38	0.792 +/-0.016	20.12 +/-0.41	0.272 +/-0.011	6.91 +/-0.28
E375	34-14-09-0137	1.351 +/-0.034	34.32 +/-0.86	0.556 +/-0.012	14.12 +/-0.30	0.385 +/-0.021	9.78 +/-0.53	0.367 +/-0.015	9.32 +/-0.38	1.025 +/-0.035	26.04 +/-0.89	0.367 +/-0.015	9.32 +/-0.38
E21	41-16-12-0162	1.600 +/-0.035	40.64 +/-0.89	0.649 +/-0.005	16.48 +/-0.13	0.415 +/-0.008	10.54 +/-0.20	0.490 +/-0.017	12.45 +/-0.43	1.145 +/-0.030	29.08 +/-0.76	0.490 +/-0.017	12.45 +/-0.43
E42/15	43-21-15-0168	1.687 +/-0.034	42.85 +/-0.86	0.831 +/-0.005	21.11 +/-0.13	0.596 +/-0.014	15.14 +/-0.36	0.468 +/-0.014	11.89 +/-0.35	1.219 +/-0.029	30.96 +/-0.74	0.608 +/-0.012	15.44 +/-0.30
E 42/20	43-21-20-168A	1.687 +/-0.034	42.85 +/-0.86	0.831 +/-0.005	21.11 +/-0.13	0.596 +/-0.014	15.14 +/-0.36	0.468 +/-0.014	11.89 +/-0.35	1.219 +/-0.029	30.96 +/-0.74	0.772 +/-0.015	19.61 +/-0.38

TSC FERRITE INTERNATIONAL COMPOSITE E CORE EFFECTIVE CORE SET PARAMETERS

PART #	MAGNETIC PATH LENGTH	EFFECTIVE CORE AREA	EFFECTIVE CORE VOLUME	WINDOW AREA	POWER HANDLING CAPABILITY INDEX	INDUCTANCE INDEX AL
	Le cm	Ae cm ²	Ve cm ³	Wa cm ²	WaAe cm ⁴	CMP1 +25%
13-06-04-0051	2.959	0.130	0.386	0.250	0.033	75
16-08-05-0063	3.761	0.199	0.750	0.398	0.082	100
19-08-05-0075	3.977	0.225	0.894	0.545	0.122	110
20-10-06-0080	4.614	0.315	1.454	0.525	0.162	120
25-10-06-0100	4.899	0.394	1.928	0.850	0.335	160
25-13-07-0099	5.775	0.517	2.983	0.956	0.494	160
30-15-07-0118	6.607	0.573	3.785	1.344	0.770	155
34-14-09-0137	6.942	0.813	5.646	1.634	1.329	230
41-16-12-0162	7.750	1.487	11.521	1.754	2.607	370
43-21-15-0168	9.834	1.838	18.075	2.888	5.308	335
43-21-20-168A	9.834	2.334	22.951	2.888	6.739	405

TSC Pyroferric

IRON POWDER / SOFT FERRITE COMPOSITE TOROIDS

TSC combines the high permeability of soft ferrite material with the inherent distributed air gap of iron powder cores resulting in a toroidal core that produces high inductance values with low dc currents and moderately high inductance values with maximum dc currents.

Below shows the percent change of inductance with increasing dc magnetizing force. The percent of ferrite material to iron powder can be varied to change the shape of these curves. Higher percentages of ferrite result in higher initial inductance with low dc magnetizing forces. Higher percentages of iron powder result in larger inductance values under maximum dc current. Choose a standard composite core or contact us with your application requirements to optimally customize a core to meet your needs.

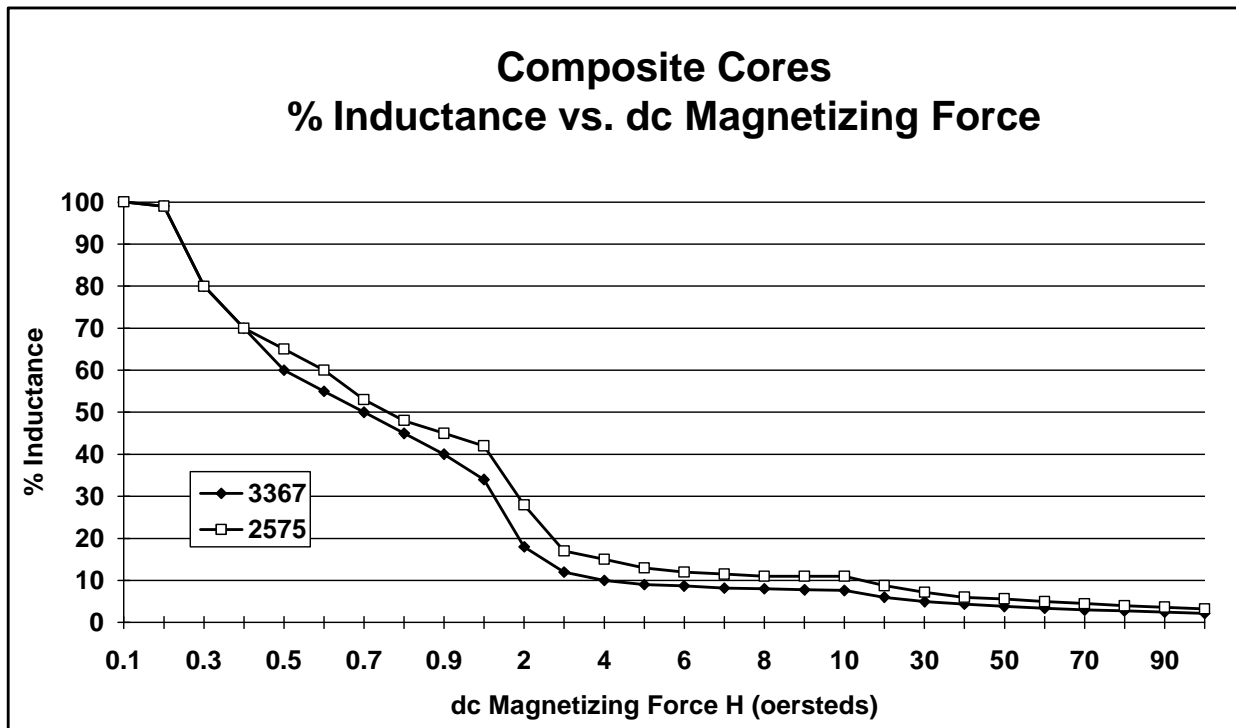

TSC Pyroferric

IRON POWDER / SOFT FERRITE COMPOSITE TOROIDS

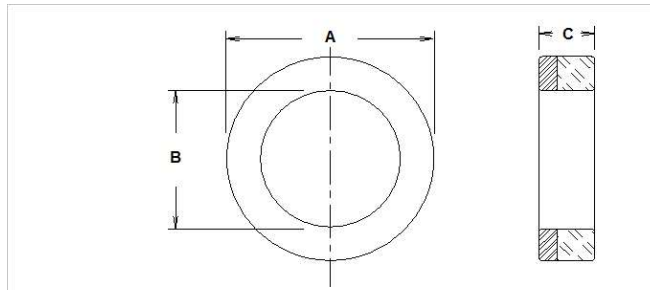

TSC PYROFERRIC COMPOSITE TOROID DIM

PART #	A		B		C	
	in	mm	in	mm	in	mm
13-07-07-3367	0.510	12.95	0.290	7.37	0.280	7.112
	+0.010	+0.25	+0.006	+0.15	+0.030	+0.76
13-07-09-2575	0.510	12.95	0.290	7.37	0.365	9.271
	+0.010	+0.25	+0.006	+0.15	+0.030	+0.76
21-13-10-3367	0.835	21.21	0.510	12.95	0.400	10.16
	+0.017	+0.43	+0.010	+0.25	+0.030	+0.76
21-13-13-2575	0.835	21.21	0.510	12.95	0.525	13.34
	+0.017	+0.43	+0.010	+0.25	+0.030	+0.76
26-15-12-3367	1.025	26.04	0.600	15.24	0.475	12.07
	+0.020	+0.51	+0.012	+0.30	+0.030	+0.76
26-15-16-2575	1.025	26.04	0.600	15.24	0.625	15.88
	+0.020	+0.51	+0.012	+0.30	+0.030	+0.76
39-21-16-3367	1.520	38.61	0.835	21.21	0.625	15.88
	+0.030	+0.76	+0.017	+0.43	+0.030	+0.76
39-21-21-2575	1.520	38.61	0.835	21.21	0.825	20.96
	+0.030	+0.76	+0.017	+0.43	+0.030	+0.76
51-31-20-3367	2.010	51.05	1.240	31.50	0.775	19.69
	+0.040	+1.02	+0.025	+0.64	+0.030	+0.76
51-31-26-2575	2.010	51.05	1.240	31.50	1.025	26.04
	+0.040	+1.02	+0.025	+0.64	+0.030	+0.76

PART #	TSC PYROFERRIC COMPOSITE TOROIDAL CORE EFFECTIVE PARAMETERS						INDUCTANCE INDEX AL nH/N ² +25%
	MAGNETIC PATH LENGTH Le cm	EFFECTIVE CORE AREA Ae cm ²	EFFECTIVE CORE VOLUME Ve cm ³	WINDOW AREA Wa cm ²	POWER HANDLING CAPABILITY INDEX WaAe cm ⁴	CORE WEIGHT GRAMS	
13-07-07-3367	3.03	0.19	0.59	0.43	0.08	3.06	630
13-07-09-2575	3.03	0.25	0.76	0.43	0.11	3.99	650
21-13-10-3367	5.16	0.41	2.12	1.32	0.54	10.87	730
21-13-13-2575	5.16	0.54	2.78	1.32	0.71	14.27	725
26-15-12-3367	6.18	0.64	3.93	1.82	1.16	20.39	940
26-15-16-2575	6.18	0.84	5.17	1.82	1.53	26.83	1000
39-21-16-3367	8.86	1.34	11.87	3.53	4.74	62.68	1410
39-21-21-2575	8.86	1.77	15.67	3.53	6.25	82.73	1450
51-31-20-3367	12.48	1.89	23.56	7.79	14.71	120.56	1430
51-31-26-2575	12.48	2.50	31.15	7.79	19.46	159.45	1470

TSC Pyroferric

Iron Powder Manufacturing Overview

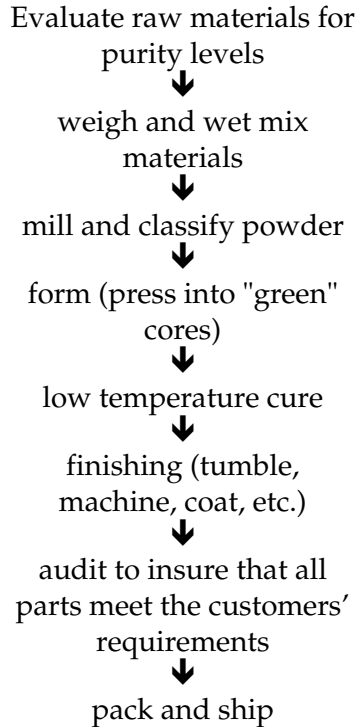

The process of manufacturing iron powder cores is made up of four basic steps: powder preparation, forming, curing, and finishing. At TSC-Pyroferric raw materials are evaluated for purity levels. After the materials are accepted they are weighed and wet mixed. The powder is further processed to make ready for the pressing operation.

The prepared iron powder is then formed into compacts, "green" cores, using mechanical presses. The cores are then low-temperature cured to set-up the organic binders.

Depending on the core configuration and customer requirements, the cores go through finishing processes. This can include tumbling, machining, coating, etc. Examples: some sleeves are centerless ground to obtain the desired OD, toroids are tumbled and coated, and threaded cores are ground with threads. Throughout the manufacturing processes the cores are tested for quality assurance.

Finally the cores are tested electrically, inspected for dimensional and visual conformance and packed to be shipped to our customers.

Iron Powder Part Identification System

FE168A-75

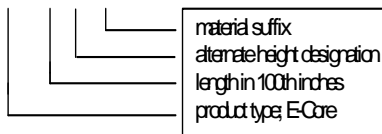

PT1060A-75

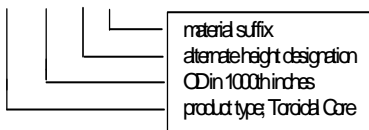

Part Number Prefix	Product Type
P1-	Threaded Cores
P2-	Bobbin Cores
P3-	Plain Cores
P4-	Non-Standard Toroids
P5-	Beads/ Sleeves/ Hollow Cores
P6-	Cup Cores
P7-	Special Shapes
PE-	Standard E-Cores
PT-	Standard Toroids

TSC Pyroferric

Samples of our standard Iron Powder core offerings can usually be supplied from stock within 24 hours. In addition to the items listed in this catalog, TSC-Pyroferric can produce a wide variety of core sizes. Please consider the core sizes shown as merely a representation of our manufacturing capability.

- The core height can be varied to accommodate special requirements.
- Other sizes and limited metric tooling is available.
- Prototypes can be hand machined for preliminary evaluation.
- Our capabilities include custom tooling.

We will be pleased to quote to your drawings and specifications on any iron powder core. Please call or FAX us today. We welcome the opportunity to serve you.

Power Conversion and Line Filter Applications

MATERIAL CHART

<u>Material Suffix</u>	<u>Permeability</u>	<u>Color Code</u>	<u>L Tolerance</u>
-33	33	White/ Gray	± 10 %
-35	35	White/ Green	± 10 %
-60	60	Gray	± 10 %
-67	67	Gray/ Green	± 10 %
-75	75	Gray/ White	± 10 %
-LL	75	Gray/ Blue	± 10 %
-85	85	White	± 10 %

INDUCTANCE FACTOR

The permeability for each material is for reference only. The cores are manufactured to a specific A_L value. The A_L values are expressed in nanohenries per turn squared (nH/ N²). To calculate the required number of turns for a specified inductance (L), use the following formula:

$$\text{required number of turns} = [L (\text{nH}) / A_L (\text{nH} / \text{N}^2)]^{0.5}$$

For the cores listed in the catalog, the A_L values are based on measurements at a frequency of 10 KHz and peak AC flux density of 10 gauss (1 millitesla). The E-cores are tested with a 100 turn coil. The toroidal cores are tested with a full single-layer winding. This produces a uniform current sheet and minimizes leakage effects.

FINISH

Toroidal core sizes PT 200 and PT 250 listed in this catalog are coated with Parylene C. The minimum dielectric strength is 250 volts.

Toroidal core sizes PT 250A and larger are coated with a polyurethane enamel. The cores are color-coded in accordance to material. The minimum dielectric strength is 500 volts. The typical dry film thickness is 4-7 mil, 10 mil maximum.

The E-cores are chemically treated to resist corrosion.

TSC Pyroferric

Iron Powder Magnetic Properties

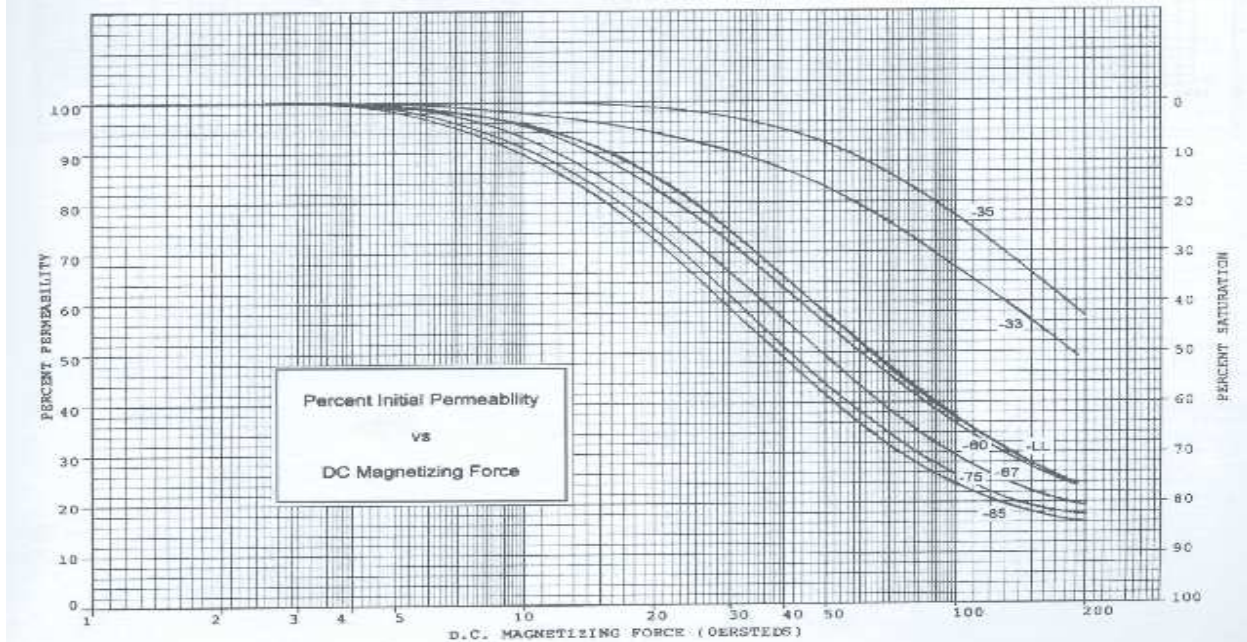
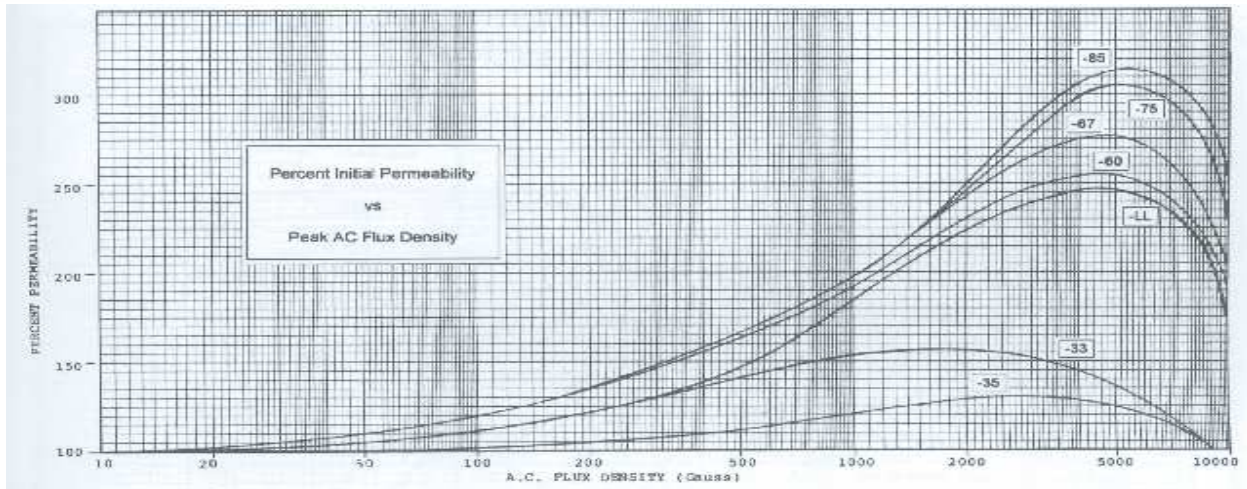
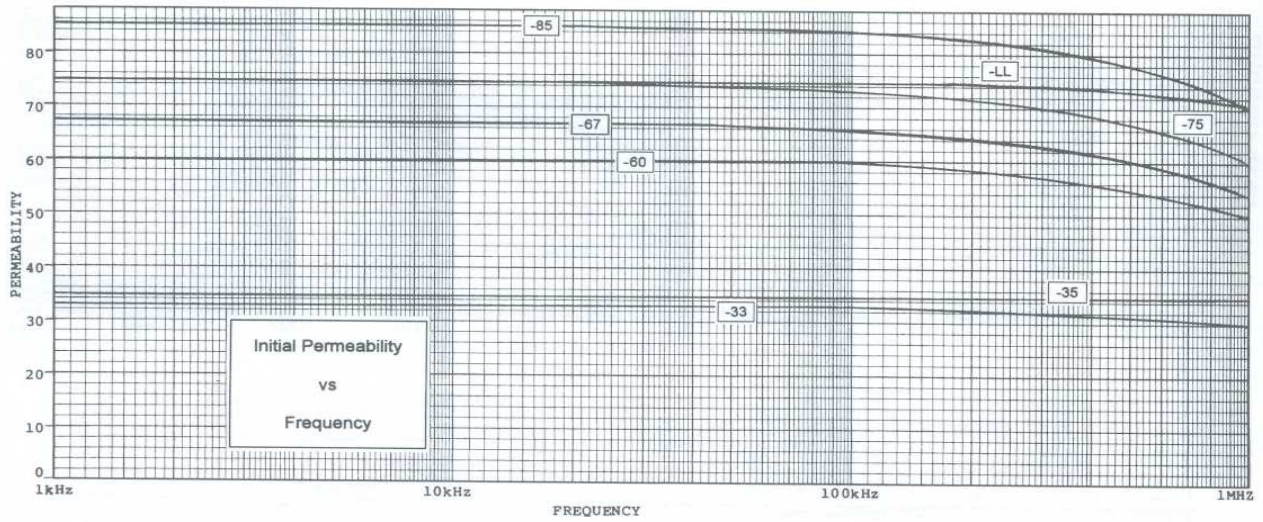

TSC Pyroferric

Iron Powder Magnetic Properties

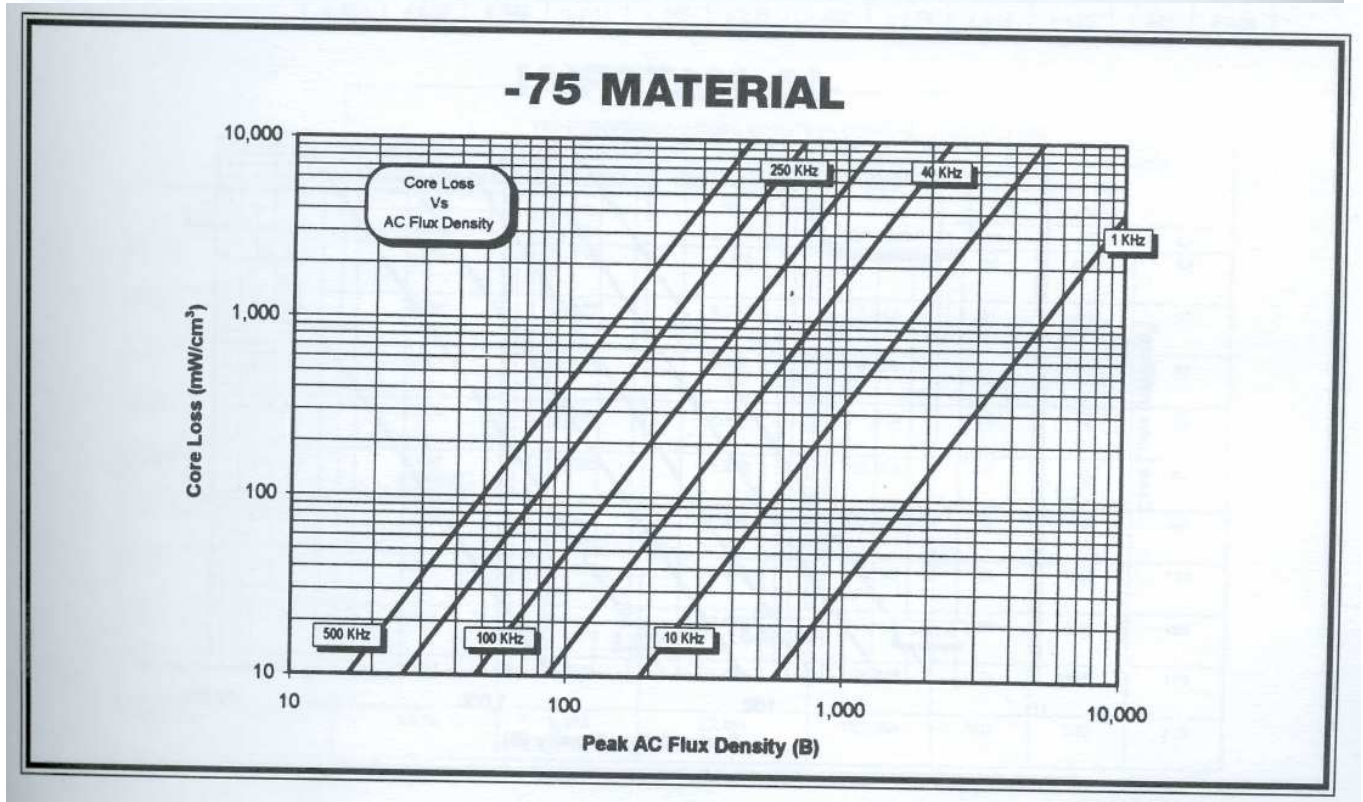
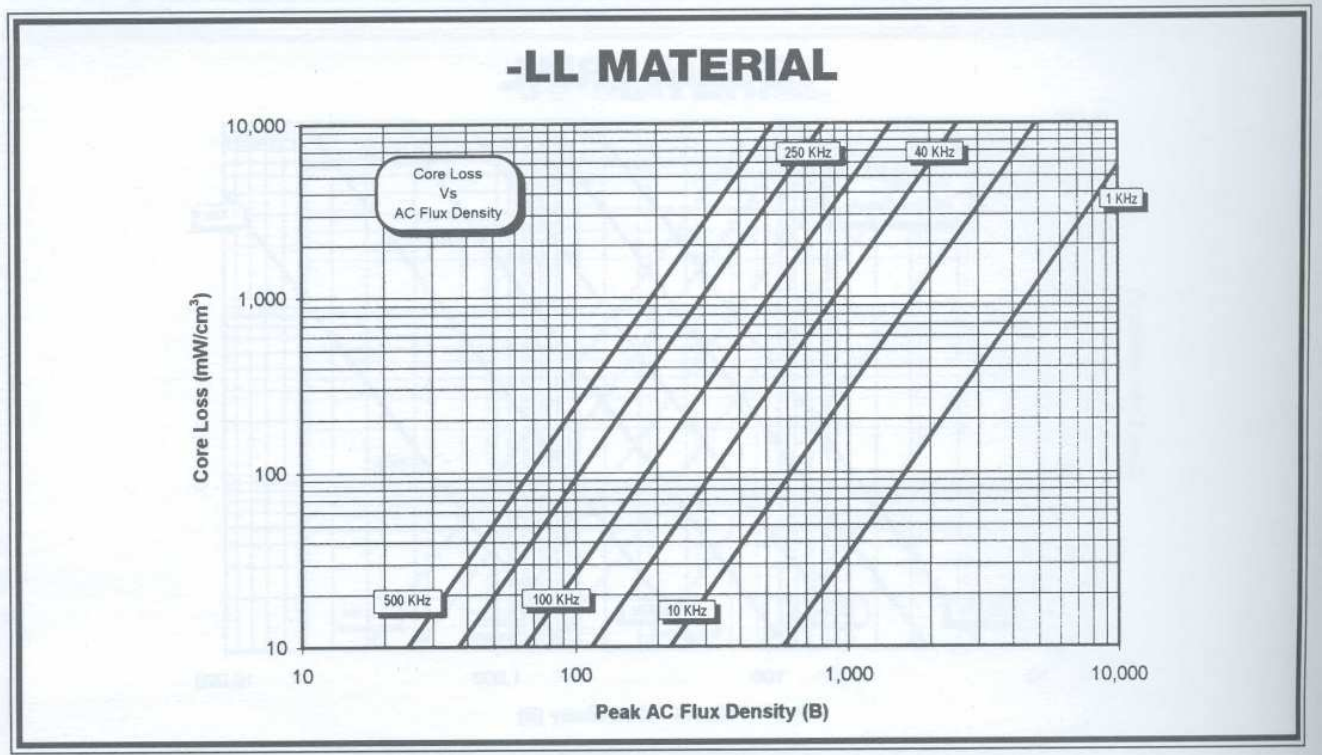

Iron Powder Magnetic Properties

TSC Pyroferric

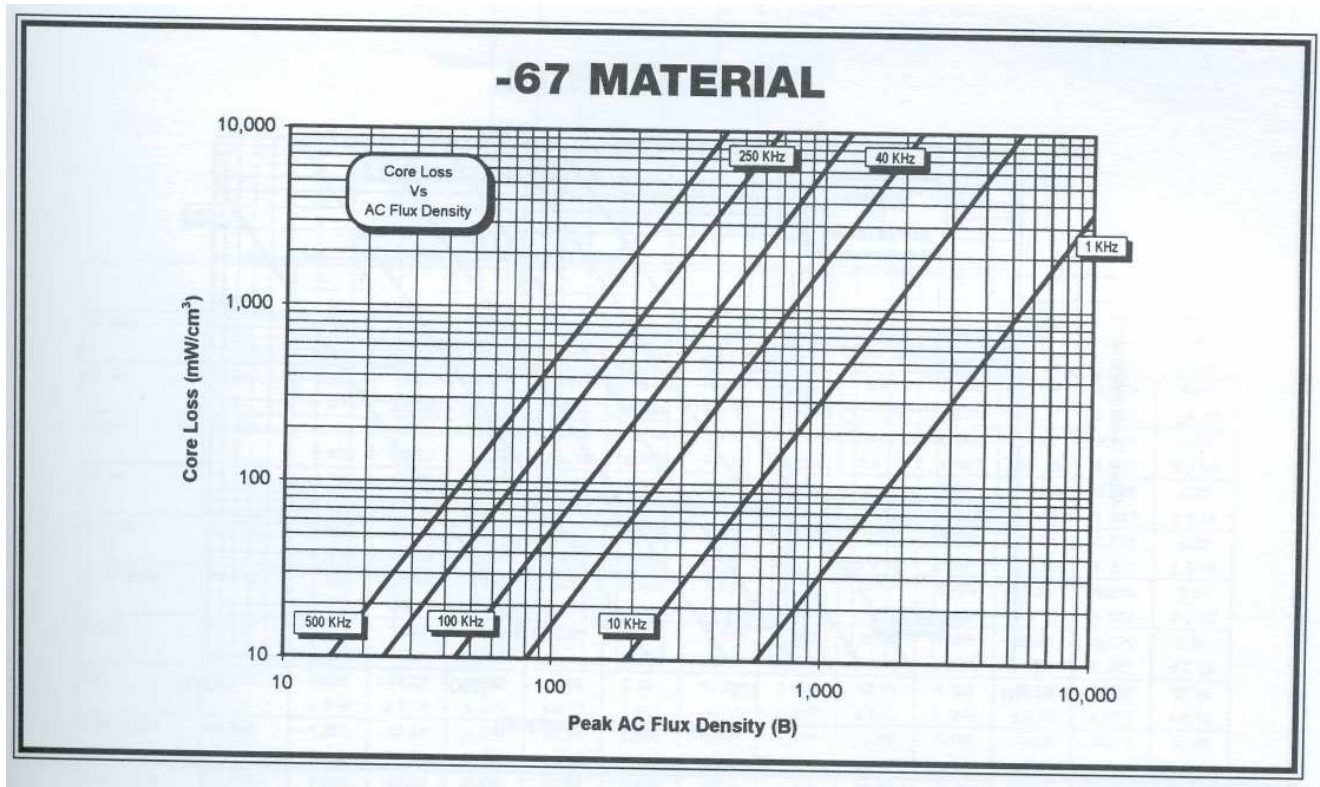
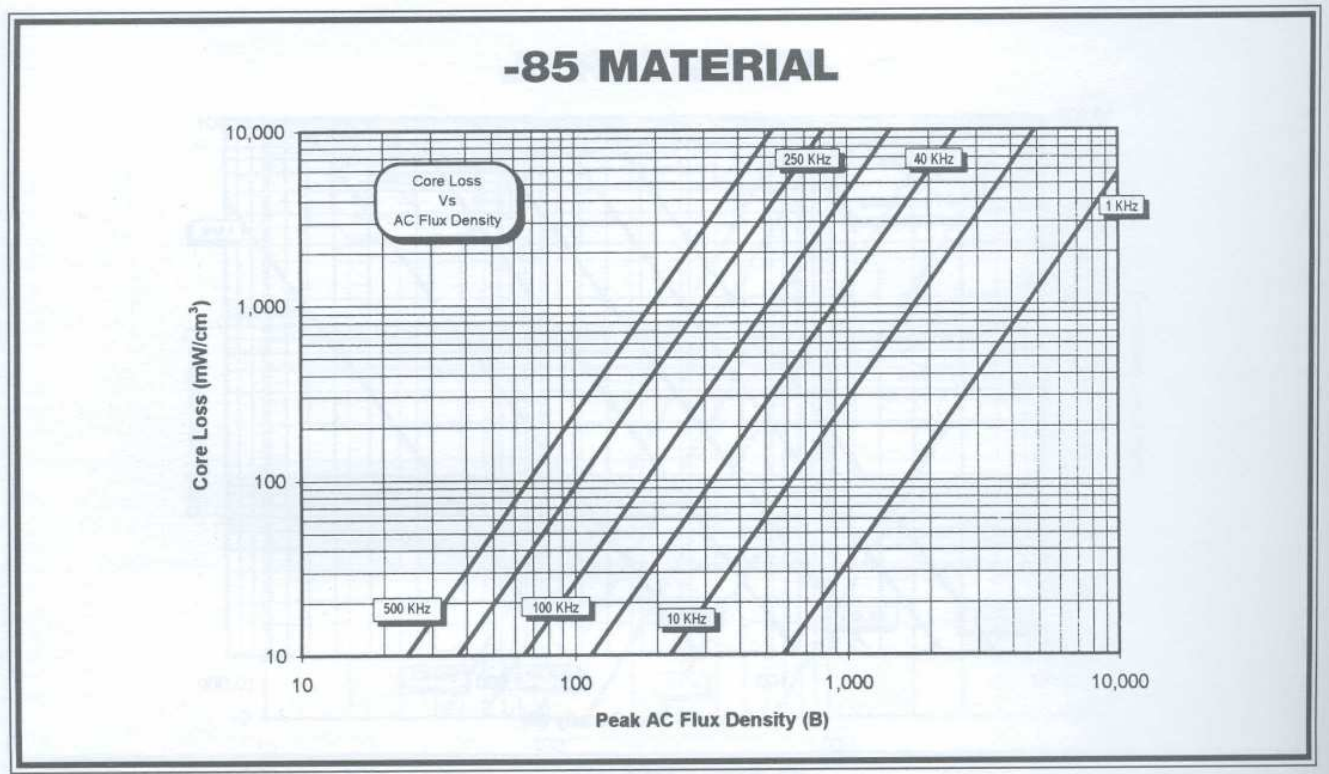

TSC Pyroferric

Iron Powder Magnetic Properties

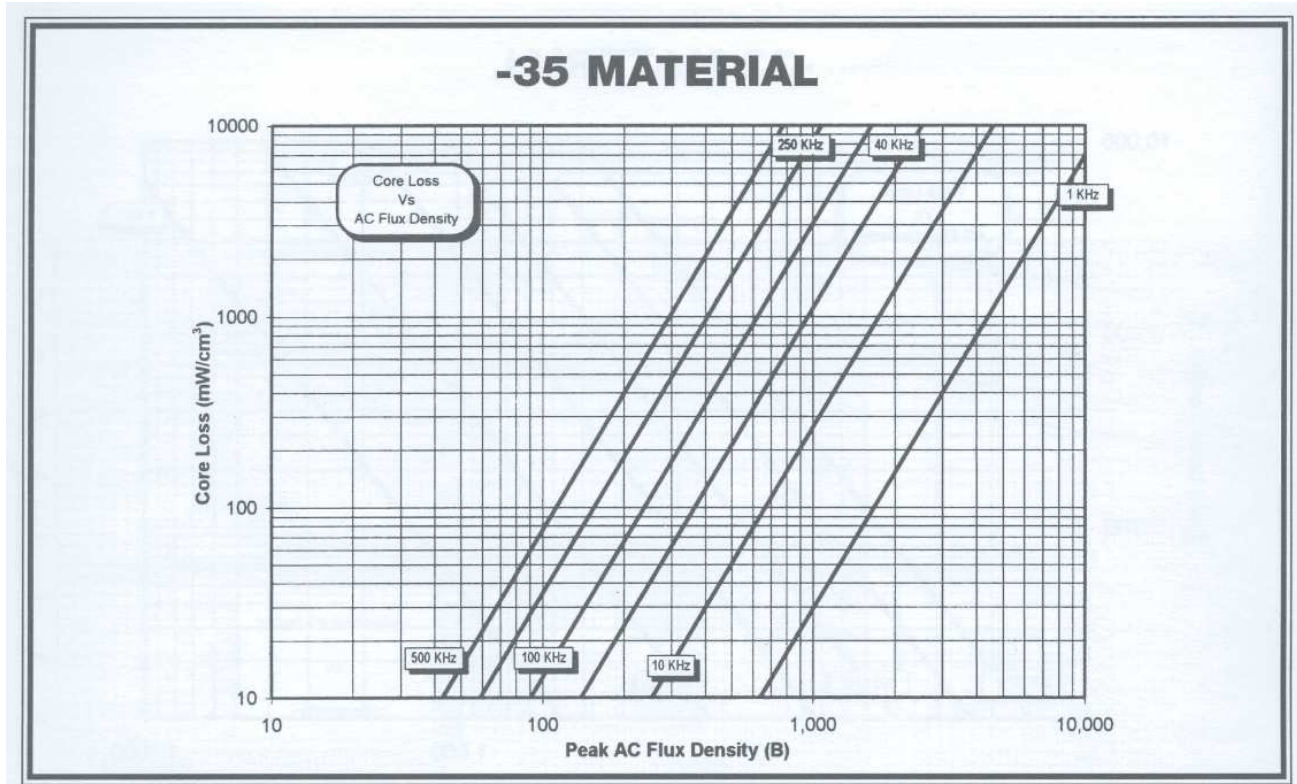
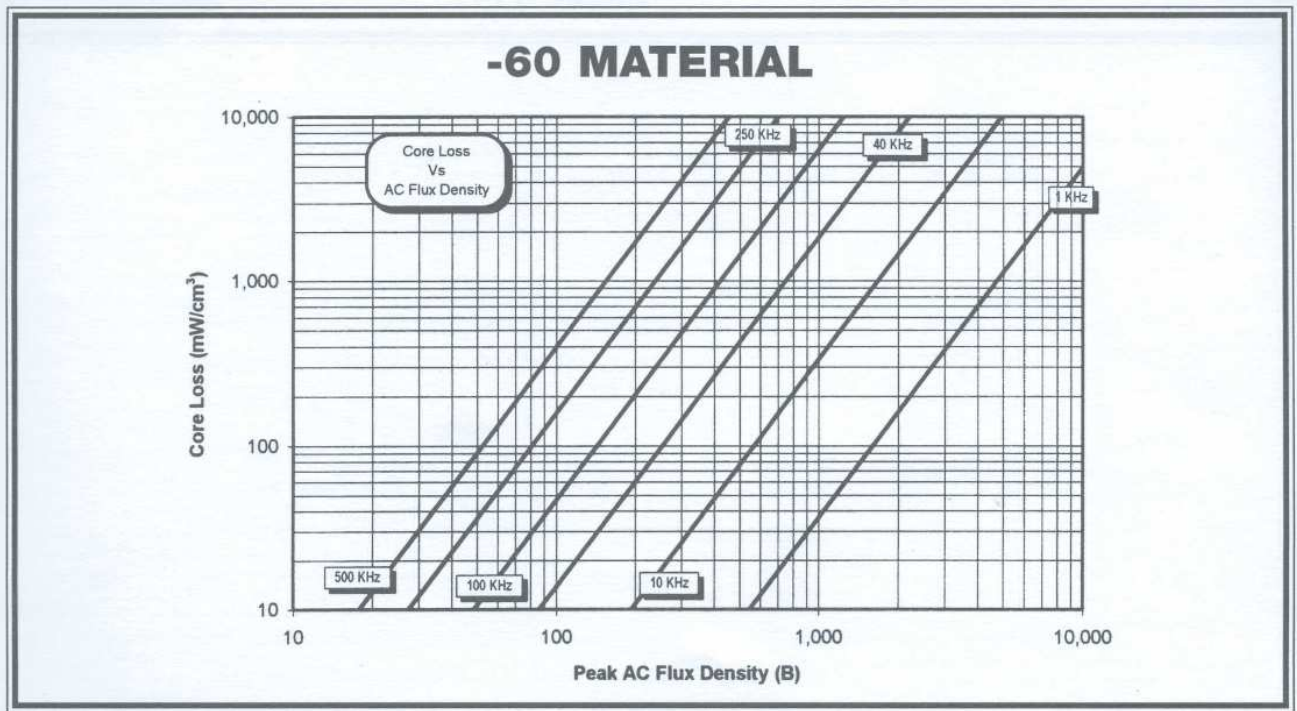

TSC Pyroferric

Iron Powder Magnetic Properties

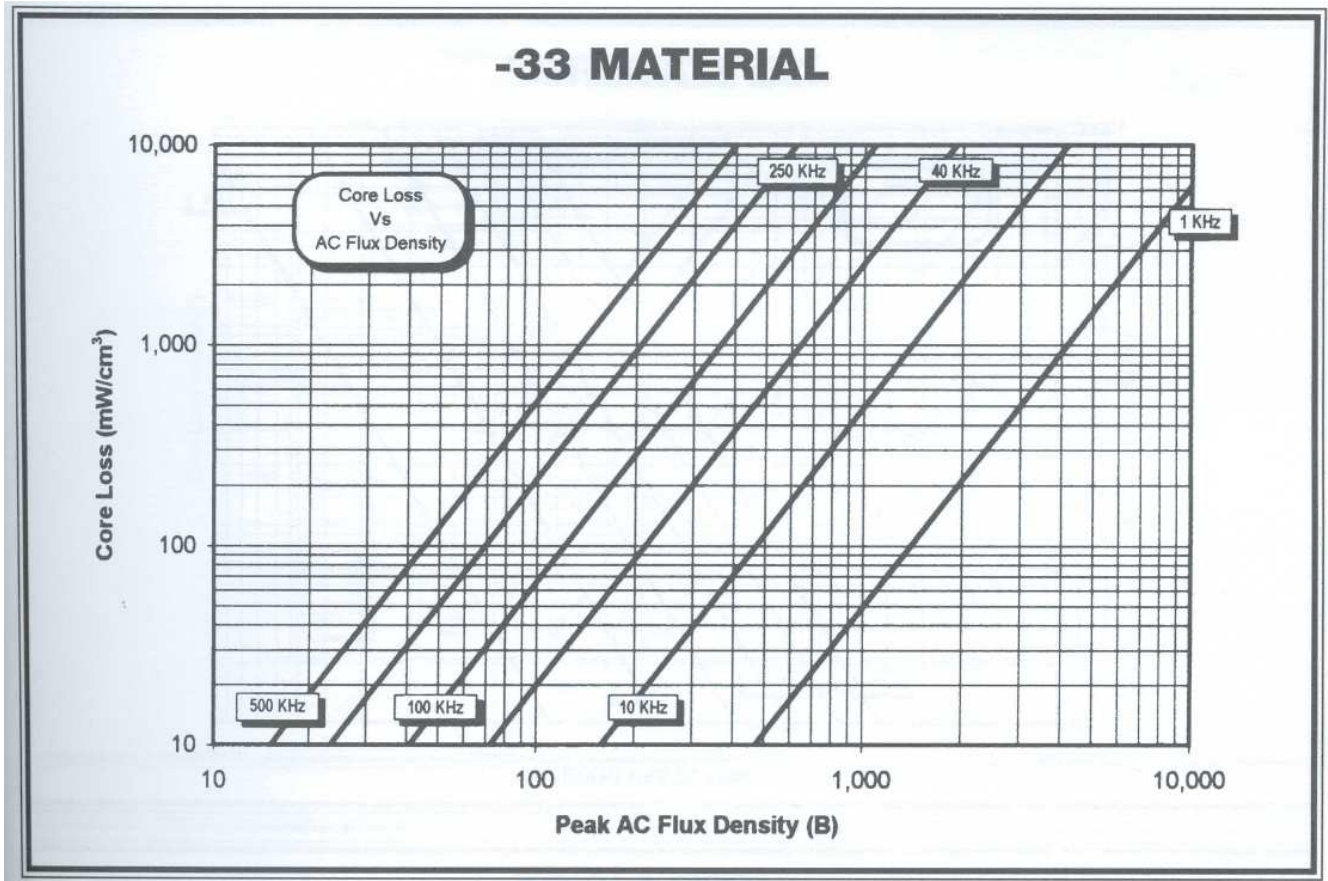

TSC Pyroferric

Cross reference of TSC-Pyroferric part number to competitor part number

TSC-PYROFERRIC PART NUMBER	MICROMETALS PART NUMBER
PT 200	T20
PT 250	-
PT 250A	T25
PT 260	T26
PT 280	T27
PT 310	T30
PT 380	T37
PT 381	T38
PT 437	-
PT 440	T44
PT 500	T50
PT 500A	T50-nnB
PT 500D	T50-nnD
PT 501	T51
PT 600	T60
PT 680	T68
PT 680A	T68-nnA

TSC-PYROFERRIC PART NUMBER	MICROMETALS PART NUMBER
PT 680D	T68-nnD
PT 720	T72
PT 800	T80
PT 800A	T80-nnB
PT 800D	T80-nnD
PT 900	T90
PT 940	T94
PT 941	-
PT 1060	T106
PT 1060A	T106-nnB
PT 1060B	T106-nnA
PT 1300	T130
PT 1301	T131
PT 1302	T132
PT 1302A	-
PT 1510	T151
PT 1570	T157

TSC-PYROFERRIC PART NUMBER	MICROMETALS PART NUMBER
PT 1750	T175
PT 1840	T184
PT 2000	T200
PT 2000B	T200-nnB
PT 2250	T225
PT 3000	T300
PT 3000D	T300-nnD
PE 51	-
PE 63	-
PE 75	E75
PE 76	-
PE 80	E80
PE 99	E99
PE 100	E100
PE 118	E118
PE 137	E137
PE 162	E162
PE 168	E168
PE 168A	E168-nnA

nn = Micrometals Material #

Pyroferric Material	Micrometals Material
-33	-33
-35	- 8
-60	--
-67	-40
-75	-26
-85	-38
-LL	-52

TSC-PYROFERRIC PART NUMBER	MICROMETALS PART NUMBER
13-07-07-3367	ST50-267
13-07-09-2575	ST50-275B
21-13-10-33-67	ST83-267
21-13-13-25-75	ST83-275B

TSC-PYROFERRIC PART NUMBER	MICROMETALS PART NUMBER
26-15-12-3367	ST102-267
26-15-16-2575	ST102-275B
39-21-16-3367	ST150-267
39-21-21-2575	ST150-275B

TSC-PYROFERRIC PART NUMBER	MICROMETALS PART NUMBER
51-31-20-3367	ST200-267
51-31-26-2575	ST200-275B

TSC Pyroferric

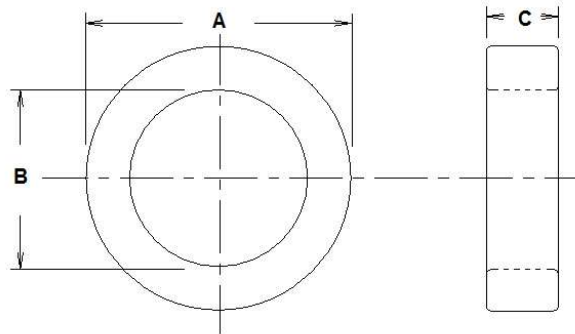

TSC PYROFERRIC TOROID DIMENSIONS

PART #	A		B		C	
	inches	mm	inches	mm	inches	mm
PT 200	0.200	5.08	0.088	2.24	0.067	1.70
	+ - 0.005	+ - 0.13	+ - 0.005	+ - 0.13	+ - 0.005	+ - 0.13
PT 250	0.200	5.08	0.125	3.18	0.063	1.60
	+ - 0.005	+ - 0.13	+ - 0.005	+ - 0.13	+ - 0.005	+ - 0.13
PT 250A	0.250	6.35	0.125	3.18	0.096	2.44
	+ - 0.005	+ - 0.13	+ - 0.005	+ - 0.13	+ - 0.005	+ - 0.13
PT 260	0.260	6.60	0.105	2.67	0.187	4.75
	+ - 0.010	+ - 0.25	+ - 0.010	+ - 0.25	+ - 0.010	+ - 0.25
PT 280	0.280	7.11	0.150	3.81	0.128	3.25
	+ - 0.010	+ - 0.25	+ - 0.010	+ - 0.25	+ - 0.010	+ - 0.25
PT 310	0.310	7.87	0.156	3.96	0.125	3.18
	+ - 0.010	+ - 0.25	+ - 0.010	+ - 0.25	+ - 0.010	+ - 0.25
PT 380	0.380	9.65	0.210	5.33	0.125	3.18
	+ - 0.010	+ - 0.25	+ - 0.010	+ - 0.25	+ - 0.010	+ - 0.25
PT 381	0.380	9.65	0.175	4.45	0.190	4.83
	+ - 0.010	+ - 0.25	+ - 0.010	+ - 0.25	+ - 0.010	+ - 0.25
PT 437	0.437	11.10	0.250	6.35	0.125	3.18
	+ - 0.010	+ - 0.25	+ - 0.010	+ - 0.25	+ - 0.010	+ - 0.25
PT 440	0.440	11.18	0.230	5.84	0.160	4.06
	+ - 0.010	+ - 0.25	+ - 0.010	+ - 0.25	+ - 0.010	+ - 0.25
PT 500	0.500	12.70	0.300	7.62	0.187	4.75
	+ - 0.010	+ - 0.25	+ - 0.010	+ - 0.25	+ - 0.010	+ - 0.25
PT 500A	0.500	12.70	0.300	7.62	0.250	6.35
	+ - 0.010	+ - 0.25	+ - 0.010	+ - 0.25	+ - 0.010	+ - 0.25
PT 500D	0.500	12.70	0.300	7.62	0.375	9.53
	+ - 0.010	+ - 0.25	+ - 0.010	+ - 0.25	+ - 0.010	+ - 0.25
PT 501	0.500	12.70	0.200	5.08	0.250	6.35
	+ - 0.010	+ - 0.25	+ - 0.010	+ - 0.25	+ - 0.010	+ - 0.25
PT 600	0.600	15.24	0.336	8.53	0.234	5.94
	+ - 0.010	+ - 0.25	+ - 0.010	+ - 0.25	+ - 0.010	+ - 0.25
PT 680	0.680	17.27	0.380	9.65	0.187	4.75
	+ - 0.010	+ - 0.25	+ - 0.010	+ - 0.25	+ - 0.010	+ - 0.25
PT 680A	0.680	17.27	0.380	9.65	0.250	6.35
	+ - 0.010	+ - 0.25	+ - 0.010	+ - 0.25	+ - 0.010	+ - 0.25
PT 680D	0.680	17.27	0.380	9.65	0.375	9.53
	+ - 0.010	+ - 0.25	+ - 0.010	+ - 0.25	+ - 0.010	+ - 0.25
PT 720	0.720	18.29	0.280	7.11	0.260	6.60
	+ - 0.010	+ - 0.25	+ - 0.010	+ - 0.25	+ - 0.010	+ - 0.25
PT 800	0.800	20.32	0.500	12.70	0.250	6.35
	+ - 0.010	+ - 0.25	+ - 0.010	+ - 0.25	+ - 0.010	+ - 0.25

Tolerances are for unpainted cores

TSC Pyroferric

PART #	TSC PYROFERRIC TOROIDAL CORE EFFECTIVE PARAMETER				INDUCTANCE INDEX AL ± 10% nH/N ²						
	MAGNETIC PATH LENGTH	EFFECTIVE CORE AREA	EFFECTIVE CORE VOLUME	CORE WEIGHT	-33	-35	-60	-67	-75	-85	-LL
	Le cm	Ae cm ²	Ve cm ³	GRAMS							
PT 200	1.030	0.023	0.024	0.19		7.8	14.5	16.5	18.5	20.0	17.5
PT 250	1.380	0.024	0.034	0.26		6.5	13.0	14.5	16.5	17.5	15.0
PT 250A	1.380	0.037	0.051	0.39		10.0	20.5	22.0	24.5	26.5	23.0
PT 260	1.280	0.090	0.116	0.97		24.0	45.5	51.0	57.0	63.0	56.0
PT 280	1.610	0.052	0.084	0.63		11.5	20.0	22.0	25.0	26.5	24.0
PT 310	1.720	0.060	0.103	0.79		14.0	26.0	29.0	32.5	34.5	30.5
PT 380	2.220	0.067	1.480	1.10		12.0	22.0	24.5	27.5	29.5	26.0
PT 381	2.010	0.120	0.240	1.89		20.0	42.0	47.0	53.0	60.0	49.0
PT 437	2.600	0.073	0.191	1.41		11.5	21.0	23.0	26.0	28.0	24.5
PT 440	2.490	0.105	0.263	1.98		18.0	31.0	33.5	37.5	41.5	35.0
PT 500	3.060	0.118	0.361	2.62		17.5	29.5	30.0	34.0	38.5	33.0
PT 500A	3.060	0.158	0.483	3.50		23.0	39.0	43.5	46.5	52.5	43.5
PT 500D	3.060	0.237	0.724	5.25			57.5	64.0	72.0	77.0	66.0
PT 501	2.440	0.266	0.550	4.59			67.0	73.5	83.0	88.5	75.0
PT 600	3.530	0.194	0.685	5.06			41.5	45.0	51.0	55.0	47.0
PT 680	4.000	0.176	0.704	5.20	18.0		34.5	39.0	43.5	45.0	40.0
PT 680A	4.000	0.235	0.941	6.96	23.5		46.5	52.0	58.0	61.0	54.0
PT 680D	4.000	0.363	1.410	10.44	36.0		68.5	76.5	86.0	92.0	80.0
PT 720	3.450	0.343	1.180	10.01	36.0		72.5	81.0	90.5	97.5	82.0
PT 800	5.000	0.238	1.188	8.53	18.0		36.5	41.0	46.0	48.5	42.0

TSC Pyroferric

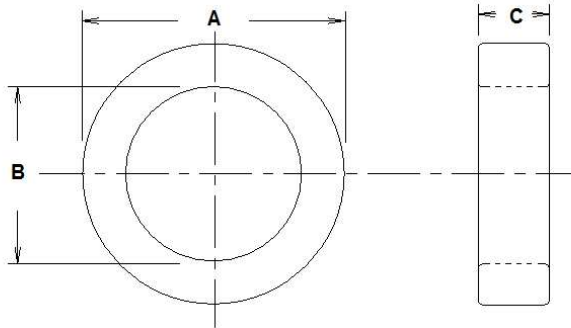

TSC PYROFERRIC TOROID DIMENSIONS

PART #	A		B		C	
	inches	mm	inches	mm	inches	mm
PT 800A	0.800	20.32	0.500	12.70	0.375	9.53
	+ - 0.010	+ - 0.25	+ - 0.010	+ - 0.25	+ - 0.010	+ - 0.25
PT 800D	0.800	20.32	0.500	12.70	0.500	12.70
	+ - 0.010	+ - 0.25	+ - 0.010	+ - 0.25	+ - 0.010	+ - 0.25
PT 900	0.900	22.86	0.550	13.97	0.375	9.53
	+ - 0.010	+ - 0.25	+ - 0.010	+ - 0.25	+ - 0.010	+ - 0.25
PT 940	0.940	23.88	0.560	14.22	0.312	7.92
	+ - 0.010	+ - 0.25	+ - 0.010	+ - 0.25	+ - 0.010	+ - 0.25
PT 941	0.940	23.88	0.630	16.00	0.250	6.35
	+ - 0.010	+ - 0.25	+ - 0.010	+ - 0.25	+ - 0.010	+ - 0.25
PT 1060	1.060	26.92	0.580	14.73	0.440	11.18
	+ - 0.015	+ - 0.38	+ - 0.015	+ - 0.38	+ - 0.015	+ - 0.38
PT 1060A	1.060	26.92	0.580	14.73	0.575	14.61
	+ - 0.015	+ - 0.38	+ - 0.015	+ - 0.38	+ - 0.015	+ - 0.38
PT 1060B	1.060	26.92	0.580	14.73	0.312	7.92
	+ - 0.015	+ - 0.38	+ - 0.015	+ - 0.38	+ - 0.015	+ - 0.38
PT 1300	1.300	33.02	0.780	19.81	0.437	11.10
	+ - 0.015	+ - 0.38	+ - 0.015	+ - 0.38	+ - 0.015	+ - 0.38
PT 1301	1.300	33.02	0.640	16.26	0.437	11.10
	+ - 0.015	+ - 0.38	+ - 0.015	+ - 0.38	+ - 0.015	+ - 0.38
PT 1302	1.300	33.02	0.700	17.78	0.437	11.10
	+ - 0.015	+ - 0.38	+ - 0.015	+ - 0.38	+ - 0.015	+ - 0.38
PT 1302A	1.300	33.02	0.700	17.78	0.217	5.51
	+ - 0.015	+ - 0.38	+ - 0.015	+ - 0.38	+ - 0.015	+ - 0.38
PT 1510	1.510	38.35	0.845	21.46	0.437	11.10
	+ - 0.015	+ - 0.38	+ - 0.015	+ - 0.38	+ - 0.015	+ - 0.38
PT 1570	1.570	39.88	0.955	24.26	0.570	14.48
	+ - 0.015	+ - 0.38	+ - 0.015	+ - 0.38	+ - 0.015	+ - 0.38
PT 1750	1.750	44.45	1.070	27.18	0.650	16.51
	+ - 0.015	+ - 0.38	+ - 0.015	+ - 0.38	+ - 0.015	+ - 0.38
PT 1840	1.840	46.74	0.950	24.13	0.710	18.03
	+ - 0.015	+ - 0.38	+ - 0.015	+ - 0.38	+ - 0.015	+ - 0.38
PT 2000	2.000	50.80	1.250	31.75	0.550	13.97
	+ - 0.015	+ - 0.38	+ - 0.015	+ - 0.38	+ - 0.015	+ - 0.38
PT 2000B	2.000	50.80	1.250	31.75	1.000	25.40
	+ - 0.015	+ - 0.38	+ - 0.015	+ - 0.38	+ - 0.015	+ - 0.38
PT 2250	2.250	57.15	1.400	35.56	0.550	13.97
	+ - 0.015	+ - 0.38	+ - 0.015	+ - 0.38	+ - 0.015	+ - 0.38
PT 3000	3.040	77.22	1.930	49.02	0.500	12.70
	+ - 0.015	+ - 0.38	+ - 0.015	+ - 0.38	+ - 0.015	+ - 0.38
PT 3000D	3.040	77.22	1.930	49.02	1.000	25.40
	+ - 0.015	+ - 0.38	+ - 0.015	+ - 0.38	+ - 0.015	+ - 0.38

Tolerances are for unpainted cores

TSC Pyroferric

PART #	TSC PYROFERRIC TOROIDAL CORE EFFECTIVE PARAMETER				INDUCTANCE INDEX AL ± 10% nH/N ²						
	MAGNETIC PATH LENGTH	EFFECTIVE CORE AREA	EFFECTIVE CORE VOLUME	CORE WEIGHT	-33	-35	-60	-67	-75	-85	-LL
	Le cm	Ae cm ²	Ve cm ³	GRAMS							
PT 800A	5.000	0.356	1.780	12.80	29.0		55.5	62.0	69.5	74.0	63.0
PT 800D	5.000	0.475	2.376	17.07	38.0		73.5	82.5	92.0	100.0	83.0
PT 900	5.560	0.415	2.306	16.66	30.0		56.5	63.0	70.5	77.5	64.0
PT 940	5.730	0.374	2.141	15.56	25.0		49.0	53.5	60.0	66.0	57.0
PT 941	5.980	0.215	1.228	9.04	16.0		30.5	34.0	38.0	41.0	35.0
PT 1060	6.160	0.661	4.074	30.31	40.0		81.0	86.0	96.0	110.0	95.0
PT 1060A	6.160	0.864	5.324	39.61	56.0		106.0	114.0	128.0	145.0	124.0
PT 1060B	6.160	0.469	2.889	21.50	30.0		53.5	60.0	67.0	78.0	67.0
PT 1300	7.950	0.717	5.702	41.37	34.0		66.0	73.0	82.0	93.0	79.0
PT 1301	7.130	0.892	6.360	48.97	46.5		94.0	105.0	118.0	130.0	108.0
PT 1302	7.490	0.819	6.138	45.89	43.5		83.0	92.0	103.0	112.0	95.0
PT 1302A	7.490	0.407	3.048	22.79	20.5		40.0	45.0	50.0	53.5	46.0
PT 1510	8.890	0.910	8.100	59.90	41.0		78.0	87.0	97.0	102.0	89.0
PT 1570	9.670	1.110	10.710	77.47	43.5		86.0	91.0	102.0	114.0	99.0
PT 1750	10.810	1.397	15.106	77.484	53.0		90.0	95.0	105.0	119.0	105.0
PT 1840	10.360	1.970	20.370	154.30	70.0		143.0	152.0	170.0	192.0	159.0
PT 2000	12.500	1.310	16.330	117.33	37.0		79.0	83.0	93.0	105.0	92.0
PT 2000B	12.500	2.380	29.690	213.33	70.0		128.0	143.0	160.0		155.0
PT 2250	14.030	1.480	20.770	149.34	37.0		78.0	88.0	98.0		92.0
PT 3000	19.163	1.760	33.724	241.41	38.0			71.0	80.0		80.0
PT 3000D	19.163	3.520	67.449	482.81	76.0			142.0	160.0		160.0

Magnetic parameters calculated per MMPA standard #UEI 310

TSC Pyroferric

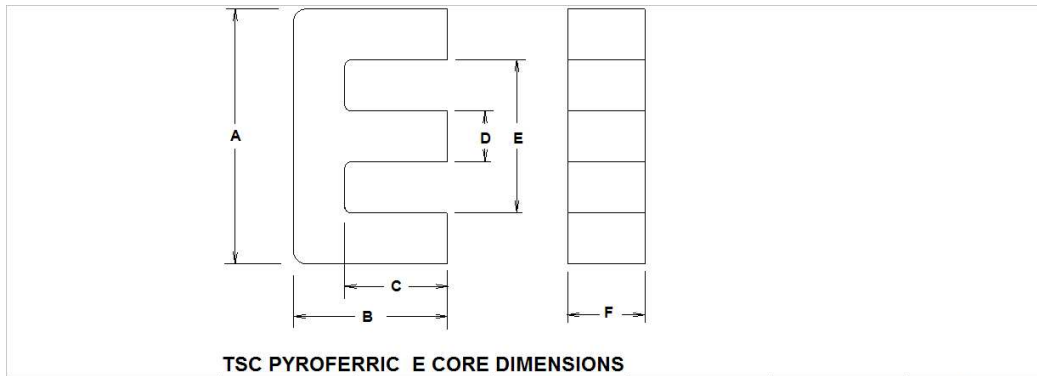

TSC PYROFERRIC E CORE DIMENSIONS

PART #	A		B		C		D		E		F		
	in	mm	in	mm	in	mm	in	mm	in	mm	in	mm	
EF 12.6	PE 51	0.498 ± .010	12.65 ± 0.25	0.252 ± .005	6.40 ± 0.13	0.184 ± .005	4.66 ± 0.13	0.140 ± .007	3.54 ± 0.18	0.362 ± .007	9.19 ± 0.18	0.140 ± .007	3.54 ± 0.18
EF 16	PE 63	0.634 ± .010	16.10 ± 0.25	0.317 ± .005	8.04 ± 0.13	0.233 ± .005	5.91 ± 0.13	0.180 ± .007	4.56 ± 0.18	0.457 ± .007	11.60 ± 0.18	0.178 ± .007	4.51 ± 0.18
E 187	PE 75	0.750 ± .010	19.05 ± 0.25	0.318 ± .005	8.06 ± 0.13	0.223 ± .005	5.65 ± 0.13	0.187 ± .007	4.75 ± 0.18	0.562 ± .007	14.27 ± 0.18	0.187 ± .007	4.75 ± 0.18
EF 20	PE 80	0.795 ± .010	20.19 ± 0.25	0.392 ± .005	9.96 ± 0.13	0.275 ± .005	6.99 ± 0.13	0.230 ± .007	5.84 ± 0.18	0.575 ± .007	14.61 ± 0.18	0.228 ± .007	5.79 ± 0.18
EF 25	PE 99	1.000 ± .010	25.40 ± 0.25	0.500 ± .005	12.70 ± 0.13	0.345 ± .005	8.76 ± 0.13	0.287 ± .007	7.29 ± 0.18	0.695 ± .007	17.65 ± 0.18	0.287 ± .007	7.29 ± 0.18
E 24/25	PE 100	1.000 ± .010	25.40 ± 0.25	0.375 ± .005	9.53 ± 0.13	0.250 ± .005	6.35 ± 0.13	0.250 ± .007	6.35 ± 0.18	0.750 ± .007	19.05 ± 0.18	0.248 ± .007	6.30 ± 0.18
E 30/15mm	PE 118	1.185 ± .010	30.10 ± 0.25	0.593 ± .005	15.05 ± 0.13	0.391 ± .005	9.93 ± 0.13	0.278 ± .007	7.06 ± 0.18	0.782 ± .007	19.86 ± 0.18	0.276 ± .007	7.01 ± 0.18
E 375	PE 137	1.375 ± .010	34.93 ± 0.25	0.563 ± .005	14.29 ± 0.13	0.375 ± .005	9.53 ± 0.13	0.375 ± .007	9.53 ± 0.18	1.000 ± .010	25.40 ± 0.25	0.375 ± .007	9.53 ± 0.18
E 21	PE 162	1.625 ± .010	41.28 ± 0.25	1.342 ± .005	34.09 ± 0.13	0.421 ± .005	10.69 ± 0.13	0.500 ± .007	12.70 ± 0.18	1.125 ± .010	28.58 ± 0.25	0.500 ± .007	12.70 ± 0.18
E 42/15mm	PE 168	1.685 ± .010	42.80 ± 0.25	0.830 ± .005	21.08 ± 0.13	0.605 ± .005	15.37 ± 0.13	0.475 ± .007	12.07 ± 0.18	1.210 ± .010	30.73 ± 0.25	0.590 ± .010	14.99 ± 0.25
E 42/20mm	PE 168A	1.685 ± .010	42.80 ± 0.25	0.830 ± .005	21.08 ± 0.13	0.605 ± .005	15.37 ± 0.13	0.475 ± .007	12.07 ± 0.18	1.210 ± .010	30.73 ± 0.25	0.787 ± .010	19.99 ± 0.25
	PE 187	1.875 ± .010	47.63 ± 0.25	0.782 ± .005	19.86 ± 0.13	0.469 ± .005	11.91 ± 0.13	0.625 ± .005	15.88 ± 0.13	1.249 ± .010	31.72 ± 0.25	0.625 ± .010	15.88 ± 0.25

PART #	TSC PYROFERRIC E CORE EFFECTIVE CORE SET PARAMETERS								
	MAGNETIC PATH LENGTH	EFFECTIVE CORE AREA	EFFECTIVE CORE VOLUME	WINDOW AREA	POWER HANDLING CAPABILITY INDEX	CORE SET WEIGHT	INDUCTANCE INDEX		
	Le cm	Ae cm ²	Ve cm ³	Wa cm ²	WaAe cm ⁴	GRAMS	AL ± 10% nH/N ²		
PE 51	2.979	0.124	0.370	0.263	0.033	2.641	-67 40	-75 45.5	-LL 44
PE 63	3.760	0.201	0.757	0.415	0.084	5.412	51	60	56
PE 75	3.971	0.227	0.908	0.538	0.122	6.455	57	64	59
PE 80	4.583	0.334	1.533	0.612	0.204	11.015	65	73	70
PE 99	5.745	0.554	3.185	0.908	0.504	22.978	81	96	96
PE 100	4.807	0.400	1.923	0.806	0.323	13.818	82	92	85
PE 118	6.539	0.605	3.958	1.271	0.769	31.103	80	90	90
PE 137	6.896	0.908	6.262	1.512	1.373	45.109	120	134	131
PE 162	7.860	1.613	12.677	1.698	2.738	92.182	188	210	199
PE 168	9.854	1.780	17.536	2.869	5.107	125.426	174	195	179
PE 168A	9.854	2.374	23.391	2.869	6.811	167.304	207	232	230
PE 187	8.847	2.523	22.318	1.888	4.763	168.28	240	268	260

Magnetic parameters calculated per MMPA standard #UEI 310

TSC Pyroferric

RF Applications

RF MATERIAL CHART

Core Material	Permeability	Toroidal Color Code	Recommended Frequency Range
Carbonyl W	6	Gray	40 MHz-250 MHz
Carbonyl J	7	Gray	35 MHz-135 MHz
Carbonyl SF	8	Yellow/ Gray	10 MHz-100 MHz
Carbonyl TH	8.5	Gray	1 MHz-60 MHz
Carbonyl E	10	Red/ Gray	100 KHz-25 MHz
Carbonyl C	20	Gray	50 KHz-5 MHz
Carbonyl GQ4 *	35	White/ Green	50 KHz-2 MHz

* For Carbonyl GQ4 (-35) toroidal cores please refer to the Power Conversion Applications section.

FINISH

Toroidal core sizes PT 125 and PT 250A listed in this catalog are coated with Parylene C. The minimum dielectric strength is 250 volts.

Toroidal core sizes PT 280 and larger are coated with a polyurethane enamel. The cores are color-coded in accordance to material. The minimum dielectric strength is 500 volts. The typical dry film thickness is 4-7 mil, 10 mil maximum.

Q & μ COMPARISON CHART

Core Material	Comments
Carbonyl W	Highest "Q" at recommended frequency range.
Carbonyl J	Higher "Q" than SF at recommended frequency range.
Carbonyl SF	Higher "Q" than TH at higher frequencies.
Carbonyl TH	Higher "Q" than E at higher frequencies.
Carbonyl E	High "Q", medium μ , high resistance, most common RF material.
Carbonyl C	Medium μ with high "Q".
Carbonyl GQ4	Medium μ with high "Q" for special applications.

TSC Pyroferric

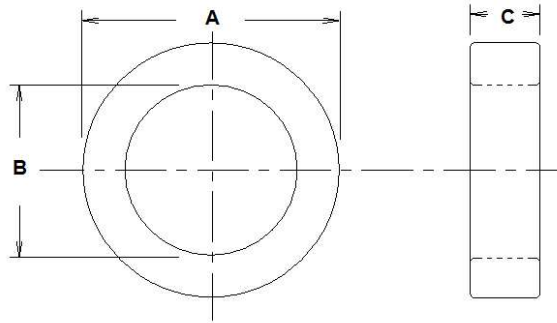

TSC PYROFERRIC RF TOROID DIMENSIONS

PART #	A		B		C	
	inches	mm	inches	mm	inches	mm
PT 125	0.125 + - 0.005	3.18 + - 0.13	0.062 + - 0.005	1.57 + - 0.13	0.050 + - 0.005	1.27 + - 0.13
PT 160	0.160 + - 0.005	4.06 + - 0.13	0.078 + - 0.005	1.98 + - 0.13	0.060 + - 0.005	1.52 + - 0.13
PT 200	0.200 + - 0.005	5.08 + - 0.13	0.088 + - 0.005	2.24 + - 0.13	0.067 + - 0.005	1.70 + - 0.13
PT 250	0.250 + - 0.005	6.35 + - 0.13	0.125 + - 0.005	3.18 + - 0.13	0.063 + - 0.005	1.60 + - 0.13
PT 250A	0.250 + - 0.005	6.35 + - 0.13	0.125 + - 0.005	3.18 + - 0.13	0.096 + - 0.005	2.44 + - 0.13
PT 280	0.280 + - 0.010	7.11 + - 0.25	0.150 + - 0.010	3.81 + - 0.25	0.128 + - 0.010	3.25 + - 0.25
PT 310	0.310 + - 0.010	7.87 + - 0.25	0.156 + - 0.010	3.96 + - 0.25	0.126 + - 0.010	3.20 + - 0.25
PT 380	0.380 + - 0.010	9.65 + - 0.25	0.210 + - 0.010	5.33 + - 0.25	0.125 + - 0.010	3.18 + - 0.25
PT 437	0.437 + - 0.010	11.10 + - 0.25	0.250 + - 0.010	6.35 + - 0.25	0.125 + - 0.010	3.18 + - 0.25
PT 440	0.440 + - 0.010	11.18 + - 0.25	0.230 + - 0.010	5.84 + - 0.25	0.160 + - 0.010	4.06 + - 0.25
PT 500	0.500 + - 0.010	12.70 + - 0.25	0.300 + - 0.010	7.62 + - 0.25	0.187 + - 0.010	4.75 + - 0.25
PT 680	0.680 + - 0.010	17.27 + - 0.25	0.380 + - 0.010	9.65 + - 0.25	0.187 + - 0.010	4.75 + - 0.25
PT 680A	0.680 + - 0.010	17.27 + - 0.25	0.380 + - 0.010	9.65 + - 0.25	0.250 + - 0.010	6.35 + - 0.25
PT 800	0.800 + - 0.010	20.32 + - 0.25	0.500 + - 0.010	12.70 + - 0.25	0.250 + - 0.010	6.35 + - 0.25
PT 940	0.940 + - 0.010	23.88 + - 0.25	0.560 + - 0.010	14.22 + - 0.25	0.312 + - 0.010	7.92 + - 0.25
PT 941	0.940 + - 0.010	23.88 + - 0.25	0.630 + - 0.010	16.00 + - 0.25	0.250 + - 0.010	6.35 + - 0.25
PT 1060	1.060 + - 0.015	26.92 + - 0.38	0.580 + - 0.015	14.73 + - 0.38	0.440 + - 0.015	11.18 + - 0.38
PT 1300	1.300 + - 0.015	33.02 + - 0.38	0.780 + - 0.015	19.81 + - 0.38	0.437 + - 0.015	11.10 + - 0.38
PT 1570	1.570 + - 0.015	39.88 + - 0.38	0.955 + - 0.015	24.26 + - 0.38	0.570 + - 0.015	14.48 + - 0.38
PT 1750	1.750 + - 0.015	44.45 + - 0.38	1.070 + - 0.015	27.18 + - 0.38	0.650 + - 0.015	16.51 + - 0.38
PT 1840	1.840 + - 0.015	46.74 + - 0.38	0.950 + - 0.015	24.13 + - 0.38	0.710 + - 0.015	18.03 + - 0.38
PT 2000	2.000 + - 0.015	50.80 + - 0.38	1.250 + - 0.015	31.75 + - 0.38	0.550 + - 0.015	13.97 + - 0.38

Tolerances are for unpainted cores

TSC Pyroferric

PART #	TSC PYROFERRIC TOROIDAL CORE EFFECTIVE PARAMETER				INDUCTANCE INDEX AL ± 10% nH/N ²					
	MAGNETIC PATH LENGTH	EFFECTIVE CORE AREA	EFFECTIVE CORE VOLUME	CORE WEIGHT	-0	-W	-SF	-TH	-E	-C
	Le cm	Ae cm ²	Ve cm ³	GRAMS						
PT 125	0.688	0.010	0.007	0.037	0.33	1.10	1.30	1.55	1.70	3.65
PT 160	0.873	0.015	0.013	0.074	0.38	1.30	1.60	1.65	2.00	4.20
PT 200	1.029	0.023	0.024	0.136	0.44	1.60	2.10	2.20	2.50	5.20
PT 250	1.382	0.024	0.034	0.186	0.38	1.50	1.75	1.85	2.20	4.20
PT 250A	1.382	0.037	0.051	0.284	0.52	2.10	2.50	2.60	3.10	7.50
PT 280	1.609	0.052	0.084	0.451	0.50	2.10	2.60	2.70	3.20	6.30
PT 310	1.720	0.060	0.103	0.566	0.73	2.55	3.25	3.30	4.00	7.10
PT 380	2.222	0.067	0.148	0.791	0.55	2.30	2.80	3.00	3.40	7.00
PT 437	2.603	0.074	0.191	1.013	0.50	2.00	2.65	2.85	3.20	6.30
PT 440	2.494	0.105	0.261	1.420	0.70	2.95	4.00	4.60	5.00	10.50
PT 500	3.057	0.118	0.361	1.887	0.64	3.10	3.30	3.70	4.30	8.20
PT 680	3.999	0.176	0.704	3.750	0.62	3.20	4.10	4.55	4.90	10.40
PT 680A	3.996	0.235	0.941	5.014	0.80	4.30	5.70	6.00	6.85	13.00
PT 800	5.000	0.238	1.188	6.149	0.68	3.30	4.15	4.70	5.40	10.80
PT 940	5.725	0.374	2.141	11.215	0.98	4.60	6.10	6.50	7.70	15.00
PT 941	6.099	0.247	1.505	7.673	0.60	3.00	3.80	3.90	4.80	9.60
PT 1060	6.163	0.661	4.074	21.844	1.60	7.80	10.00	10.50	12.50	28.00
PT 1300	7.949	0.717	5.702	29.808			8.80	9.40	11.00	20.00
PT 1570	9.671	1.108	10.714	55.821			10.50	11.50	13.00	28.00
PT 1750	10.810	1.397	15.106	56.973			12.50	13.00	15.00	30.00
PT 1840	10.360	1.966	20.365	111.183			17.50	20.00	23.50	50.00
PT 2000	12.501	1.306	16.332	84.546			9.50	10.50	12.00	24.00

Magnetic parameters calculated per MMPA standard #UEI 310

TSC Pyroferric

ROD CORES

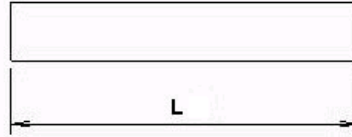

D in.	L in.	L/D ratio	Materials and Part Numbers							
			E	TH	SF	J	W	C	-60	
0.060	0.328	5.5	P3-1866							
0.062	0.035	0.6			P3-2743					
0.062	0.175	2.8			P3-2606					
0.062	0.187	3.0				P5-3972				
0.062	0.187	3.0	P3-4565							
0.080	0.200	2.5			P3-3643					
0.080	0.230	2.9			P3-3655					
0.080	0.275	3.4	P3-4647							
0.100	0.250	2.5				P3-1536				
0.100	0.312	3.1			P3-1809					
0.100	0.500	5.0				P3-2152				
0.105	0.170	1.6					P32497			
0.105	0.200	1.9					P3-2146			
0.105	0.230	2.2					P3-1058			
0.105	0.250	2.4	P3-2258						P3-2324	
0.105	0.315	3.0	P3-4657							
0.105	0.360	3.4	P3-1931						P3-1661	
0.120	0.270	2.3					P3-2740			
0.120	0.300	2.5					P3-2662			
0.120	0.345	2.9					P3-2135			
0.120	0.500	4.2	P3-2929	P3-1426						
0.125	0.170	1.4					P3-2277			
0.125	0.230	1.8					P31058			
0.125	0.375	3.0	P3-3696						P3-3169	
0.145	0.375	2.6	P3-1523							
0.145	0.445	3.1	P3-1878							
0.145	0.455	3.1	P3-4836							
0.145	0.625	4.3	P3-2690							
0.170	0.375	2.2	P3-1940							
0.170	0.500	2.9	P3-1978							
0.187	0.255	1.4				P3-3575				
0.187	0.312	1.7		P3-2583						
0.187	0.500	2.7				P3-3580		P3-3566		
0.187	0.750	4.0								P3-2693
0.195	0.625	3.2	P3-1830							
0.195	0.750	3.8	P3-1771							
0.245	0.750	3.1			P3-2595					P3-2697
0.245	1.000	4.1		P3-2057						P3-2060
0.245	1.250	5.1	P3-1091							P3-4300
0.250	0.500	2.0	P3-1859							
Test Frequency			10 MHz	40 MHz	40 MHz	40 MHz	100 MHz	10 MHz		

Electrical values based upon TSC-PYROFERRIC's standard core at the specified test frequency.

Q tolerance $\pm 7\frac{1}{2}\%$

Permeability Tolerance $\pm 4\%$

TSC Pyroferric

ROD CORES

D in.	L in.	L/D ratio	Materials and Part Numbers									
			E	TH	SF	J	W	C	-60	-67	-75	
0.250	0.750	3.0			P3-2595					P3-4689	P3-4880	
0.250	0.875	3.5							P3-3794			
0.250	1.000	4.0	P3-2057	P3-1133							P3-4456	
0.250	1.125	4.5										P3-4768
0.250	1.250	5.0	P3-1091							P3-4859	P3-4318	
0.365	0.375	1.0	P3-1466									
0.365	0.500	1.4	P3-2270									
0.365	0.750	2.1		P3-1002		P3-1547						
0.365	0.875	2.4		P3-2229								
0.365	1.000	2.7			P3-1398	P3-2163						
0.375	0.750	2.0		P3-3664								
0.375	1.000	2.7	P3-3607								P3-4777	
0.375	1.190	3.2	P3-4901									
0.375	1.250	3.3									P3-4892	
0.375	1.500	4.0	P3-4841			P3-1547						
0.433	0.625	1.4						P3-1507				
0.500	0.440	0.9	P3-4145									
0.500	0.750	1.5	P3-4702									
0.500	1.000	2.0	P3-3606								P3-4842	
0.500	1.125	2.3						P3-1571				
0.500	1.375	2.8	P3-4656								P3-4819	
0.500	1.500	3.0	P3-4194									
0.500	2.000	4.0										P3-3680
0.630	0.380	0.6	P3-4906									
0.750	0.437	0.6	P3-2443									
0.750	1.000	1.3	P3-2594								P3-4867	
0.750	1.250	1.7	P3-4808									
0.750	1.500	2.0							P3-4752			
1.000	1.000	1.0	P3-4747						P4-4879			
1.000	1.250	1.3	P3-4807									
1.000	1.500	1.5		P3-4887	P3-4888					P3-4831		
1.500	1.250	0.8	P3-4926									
1.500	1.500	1.0	93-2970									
Test Frequency			10 MHz	40 MHz	40 MHz	40 MHz	100 MHz	10 MHz				

Electrical values based upon TSC-PYROFERRIC's standard core at the specified test frequency.

Q tolerance ± 7½ %

Permeability Tolerance ± 4 %

Insert Coils

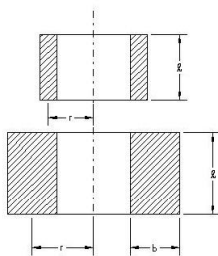

Approximate Inductance

Single layer winding

$$L = \text{effective core perm} * (r * N)^2 / (9 * r + 10 * l)$$

multi-layer winding

$$L = \text{effective core perm} * 0.8 * (r * N)^2 / (6 * r + 9 * l + 10 * b)$$

L = Inductance in micro-henries

r = mean radius to center of winding in inches

N = Turn count

l = length of coil in inches

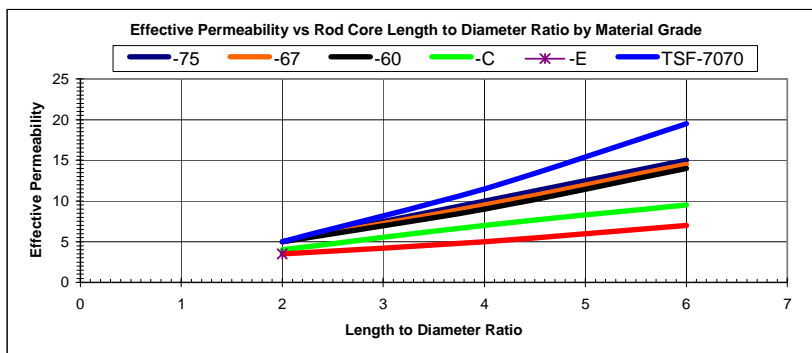

TSC Pyroferric

THREADED CORES

4-40 series

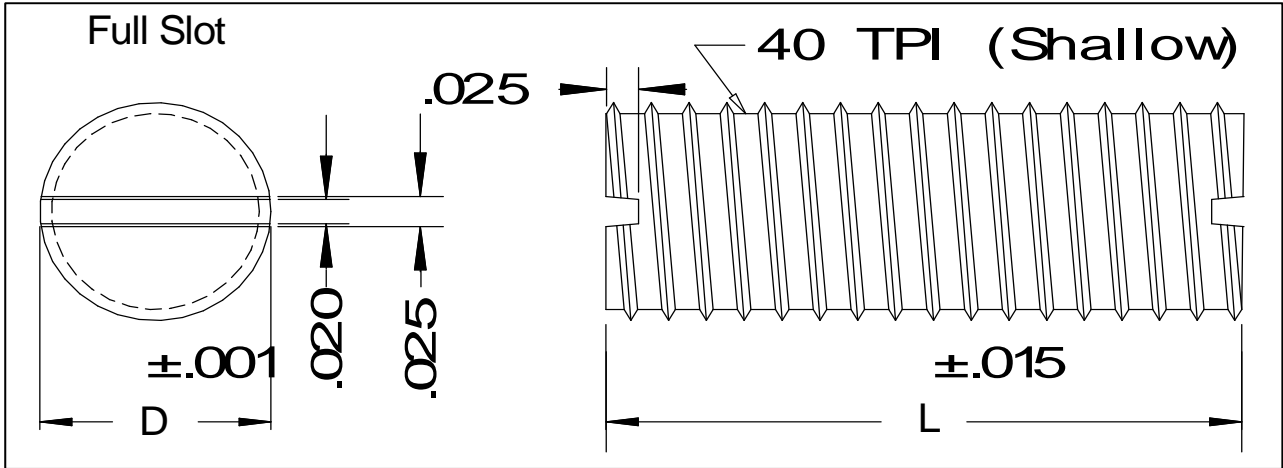

D in.	L in.	Materials and Part Numbers					
		E	TH	SF	J	W	C
0.109	0.187	P1-3401	P1-3405	P1-3409	P1-3413	P1-3417	P1-3424
	0.25	P1-3402	P1-3406	P1-3410	P1-3414	P1-3418	P1-3425
	0.312	P1-3403	P1-3407	P1-3411	P1-3415	P1-3419	P1-3426
	0.375	P1-3404	P1-3408	P1-3412	P1-3416	P1-3420	P1-3427
Test Frequency		10 MHz	40 MHz	40 MHz	40 MHz	100 MHz	10 MHz

Any length available in range 0.125 to 0.375 inches.

Teflon Coating Available

SPECIFICATIONS

Electrical values based upon *TSC-PYROFERRIC's* standard core at the specified test frequency.

Q tolerance $\pm 7\frac{1}{2}\%$ Permeability Tolerance $\pm 4\%$

All other specifications are in accordance with MPIF Standards for iron powder cores.

TSC Pyroferric

THREADED CORES

6-32 series

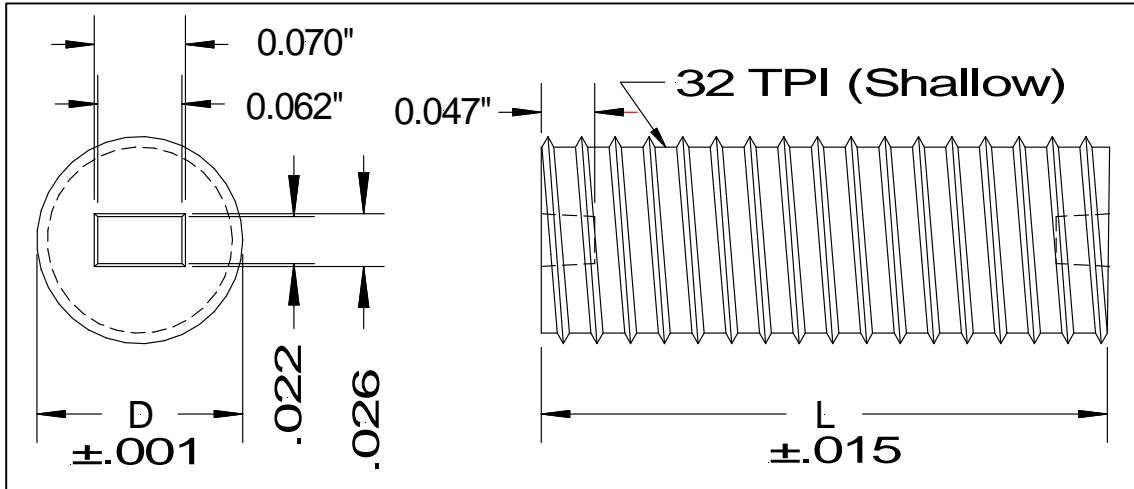

D in.	L in.	Materials and Part Numbers					
		E	TH	SF	J	W	C
0.129	0.187	P1-2343	P1-2392	P1-2391	P1-2386	P1-2828	P1-3444
	0.250	P1-2334	P1-2640	P1-2393	P1-1943	P1-2802	P1-2808
	0.312	P1-2297	P1-3433	P1-3436	P1-2298	P1-2389	P1-2296
	0.375	P1-2294	P1-3434	P1-2339	P1-2295	P1-2384	P1-2293
	0.500	P1-3432	P1-3435	P1-3437	P1-2373	P1-3438	P1-3445
Test Frequency		10 MHz	40 MHz	40 MHz	40 MHz	100 MHz	10 MHz

Any length available in range 0.125 to 0.500 inches.
Teflon Coating Available

SPECIFICATIONS

Electrical values based upon *TSC-PYROFERRIC's* standard core at the specified test frequency.
Q tolerance $\pm 7\frac{1}{2}\%$ Permeability Tolerance $\pm 4\%$

All other specifications are in accordance with MPIF Standards for iron powder cores.

TSC Pyroferric

THREADED CORES

8-32 series

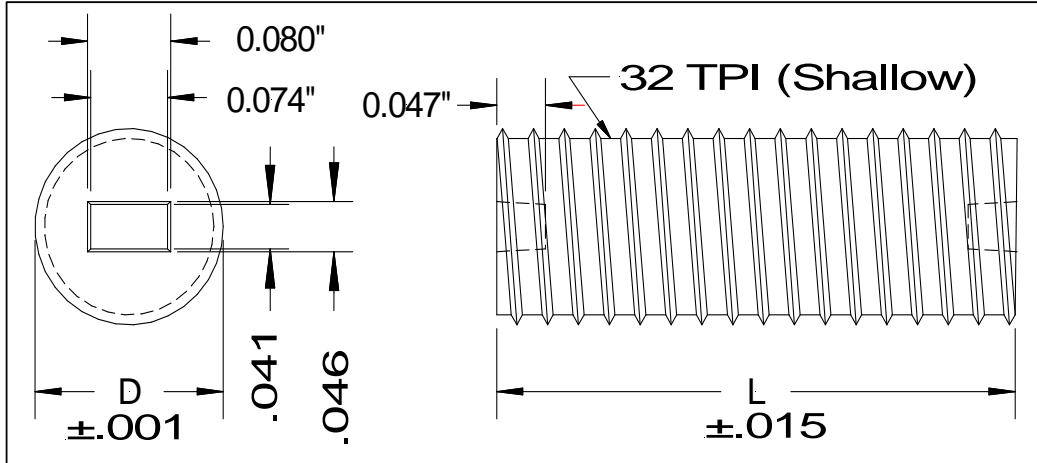

D in.	L in.	Materials and Part Numbers					
		E	TH	SF	J	W	C

0.160	0.187	P1-2658	P1-2337	P1-2647	P1-2589	P1-3457	P1-3466
	0.250	P1-2261	P1-3451	P1-1988	P1-2422	P1-3458	P1-3467
	0.312	P1-3449	P1-2872	P1-2873	P1-3454	P1-3459	P1-3468
	0.375	P1-2262	P1-2874	P1-1116	P1-3455	P1-3460	P1-3469
	0.500	P1-3450	P1-3452	P1-3453	P1-3456	P1-3461	P1-3470
Test Frequency		10 MHz	40 MHz	40 MHz	40 MHz	100 MHz	10 MHz

Any length available in range 0.125 to 0.500 inches.
Teflon Coating Available

SPECIFICATIONS

Electrical values based upon TSC-PYROFERRIC's standard core at the specified test frequency.

Q tolerance $\pm 7\frac{1}{2}\%$ Permeability Tolerance $\pm 4\%$

All other specifications are in accordance with MPIF Standards for iron powder cores.

TSC Pyroferic

THREADED CORES 10-32 series

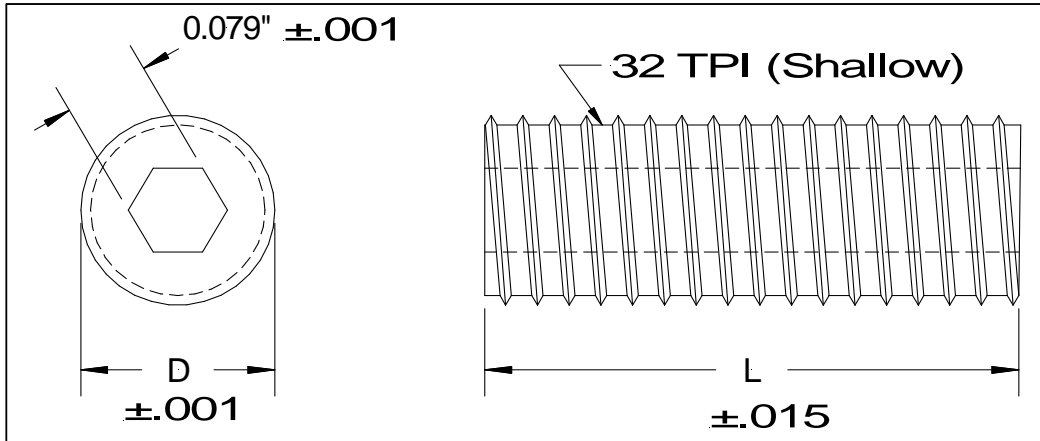

D in.	L in.	Materials and Part Numbers					
		E	TH	SF	J	W	C

0.181	0.187	P1-1925	P1-3481	P1-3484	P1-3487	P1-3488	P1-3498
	0.25	P1-1934	P1-2858	P1-2362	P1-2139	P1-3489	P1-1948
	0.312	P1-2037	P1-1929	P1-2179	P1-1921	P1-3490	P1-1947
	0.375	P1-2051	P1-2860	P1-2361	P1-2070	P1-2856	P1-2309
	0.437	P1-1944	P1-2824	P1-3485	P1-2810	P1-3491	P1-2882
	0.5	P1-2323	P1-3482	P1-2375	P1-1937	P1-3492	P1-2329
	0.625	P1-2317	P1-3483	P1-3486	P1-2332	P1-3493	P1-2850
Test Frequency		10 MHz	40 MHz	40 MHz	40 MHz	100 MHz	10 MHz

Any length available in range 0.125 to 0.625 inches.
Teflon Coating Available

SPECIFICATIONS

Electrical values based upon TSC-PYROFERRIC's standard core at the specified test frequency.
Q tolerance $\pm 7\frac{1}{2}\%$ Permeability Tolerance $\pm 4\%$

All other specifications are in accordance with MPIF Standards for iron powder cores.

TSC Pyroferric

THREADED CORES

1/4-28 series

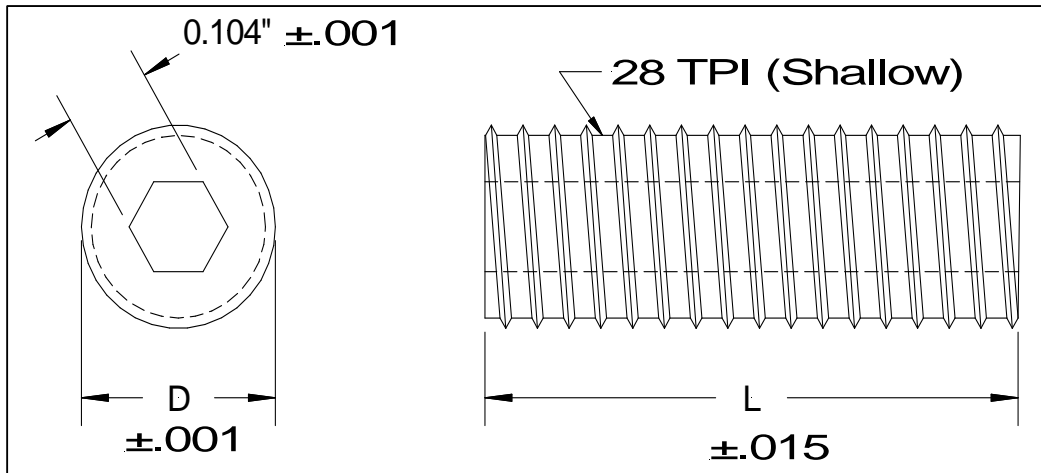

D in.	L in.	Materials and Part Numbers					
		E	TH	SF	J	W	C

0.249	0.250	P1-5111	P1-5112	P1-1942	P1-1938	P1-2350	P1-3535
	0.312	P1-1912	P1-3518	P1-3520	P1-2335	P1-3525	P1-3536
	0.375	P1-5101	P1-5110	P1-2360	P1-5113	P1-2385	P1-2071
	0.437	P1-2379	P1-3519	P1-3521	P1-3523	P1-1401	P1-3537
0.248	0.500	P1-5109	P1-2344	P1-2341	P1-5115	P1-3526	P1-2848
	0.625	P1-5106	P1-2883	P1-2803	P1-1919	P1-3527	P1-2849
0.249	0.750	P1-1776	P1-1238	P1-3522	P1-3524	P1-3528	P1-3538
Test Frequency		10 MHz	40 MHz	40 MHz	40 MHz	100 MHz	10 MHz

Any length available in range 0.125 to 0.750 inches.

Teflon Coating Available

SPECIFICATIONS

Electrical values based upon *TSC-PYROFERRIC's* standard core at the specified test frequency

Q tolerance $\pm 7\frac{1}{2}\%$ Permeability Tolerance $\pm 4\%$

All other specifications are in accordance with MPIF Standards for iron powder cores.

TSC Pyroferric

PLAIN BOBBIN CORES

TSC-PYROFERRIC manufactures more than 200 various bobbin cores, both of its own design and to customer's specifications. All bobbin cores are electrically controlled to a wound bobbin inductance value, within narrow tolerance limits. This type of control insures uniformity, which reduces the customer's winding cost.

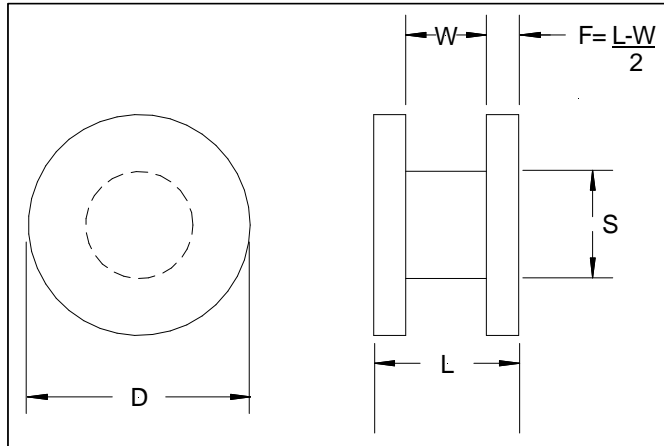

Part Number	Material	L/ 100 turns mH					Nominal Winding Area in.2 mm ²	Average Turn Length ft. cm
			D in. mm	L in. mm	W in. mm	S in. mm		
P2-4212	SF	20.8	0.047	0.075	0.035	0.028	0.00038	0.0094
P2-4211	E	21.6	1.19	1.9	0.89	0.71	0.2492	0.2859
P2-4512	35	28.4						
P2-2513	SF	29.6	0.063	0.105	0.045	0.033	0.00067	0.0126
P2-2512	E	32	1.6	2.67	1.14	0.84	0.4332	0.3833
P2-4866	35	41.6						
P2-2942	SF	38	0.08	0.1	0.045	0.045	0.00079	0.0164
P2-2943	E	39.6	2.03	2.54	1.14	1.14	0.5073	0.4979
P2-3062	35	54						
P2-3063	SF	51.2	0.093	0.09	0.04	0.05	0.00086	0.0187
P2-2610	E	54	2..36	2.29	1.02	1.27	0.5559	0.5702
P2-3064	35	66						
P2-2983	SF	40.8	0.1	0.11	0.055	0.05	0.00137	0.0196
P2-2480	E	47.6	2.54	2.79	1.4	1.27	0.889	0.5985
P2-3065	35	64						
P2-3203	SF	66	0.125	0.125	0.051	0.063	0.00158	0.0246
P2-3202	E	69.2	3.18	3.18	1.3	1.6	1.103	0.7493
P2-4718	35	90.7						
P2-1152	SF	61.9	0.147	0.147	0.068	0.07	0.00262	0.0284
P2-1767	E	69.9	3.73	3.73	1.73	1.78	1.687	0.8655
P2-4665	35	84.5						
P2-3068	SF	66	0.187	0.16	0.08	0.076	0.00444	0.0344
P2-3206	E	68	4.75	4.06	2.03	1.93	2.862	1.049
P2-3069	35	86.3						

TSC Pyroferric

PLAIN BOBBIN CORES

TSC-PYROFERRIC manufactures more than 200 various bobbin cores, both of its own design and to customer's specifications. All bobbin cores are electrically controlled to a wound bobbin inductance value, within narrow tolerance limits. This type of control insures uniformity, which reduces the customer's winding cost.

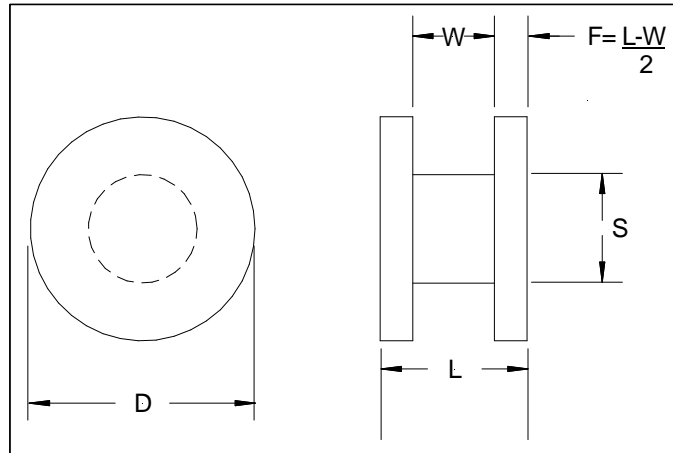

Part Number	Material	L/ 100 turns mH					Nominal Winding Area in.2 mm2	Average Turn Length ft. cm
			D in. mm	L in. mm	W in. mm	S in. mm		

P2-2691	SF	100	0.2	0.25	0.127	0.128	0.00457	0.0429
P2-3205	E	105	5.08	6.35	3.23	3.25	2.955	1.308
P2-4937	35	135						
P2-1972	SF	105.3	0.25	0.187	0.063	0.093	0.00494	0.0449
P2-1598	E	129.4	6.35	4.75	1.6	2.36	3.192	1.368
P2-4094	35	165.2						
P2-3072	SF	77.5	0.25	0.225	0.125	0.098	0.0095	0.0455
P2-1063	E	92.4	6.35	5.72	3.18	2.49	6.118	1.388
P2-3073	35	117						
P2-2799	SF	115.8	0.31	0.25	0.125	0.14	0.01062	0.0589
P2-1459	E	145.5	7.87	6.35	3.18	3.56	6.831	1.795
P2-3074	35	180.8						
P2-2798	SF	159.2	0.35	0.25	0.14	0.167	0.01281	0.0677
P2-1029	E	167.6	8.89	6.35	3.56	4.24	8.277	2.062
P2-3075	35	210						
P2-3076	SF	194.2	0.375	0.445	0.25	0.25	0.01562	0.0818
P2-2673	E	205	9.52	11.3	6.35	6.35	10.06	2.493
P2-3077	35	280.1						
P2-3078	SF	192	0.437	0.281	0.157	0.219	0.01711	0.0858
P2-3204	E	200	11.1	7.14	3.99	5.56	11.05	2.617
P2-3079	35	252						
P2-3080	SF	246.9	0.5	0.25	0.125	0.25	0.01562	0.0982
P2-1313	E	314	12.7	6.35	3.18	6.35	10.06	2.992
P2-3081	35	393.7						

TSC Pyroferric

SLOTTED BOBBIN CORES

TSC-PYROFERRIC manufactures more than 200 various bobbin cores, both of its own design and to customer's specifications. All bobbin cores are electrically controlled to a wound bobbin inductance value, within narrow tolerance limits. This type of control insures uniformity, which reduces the customer's winding cost.

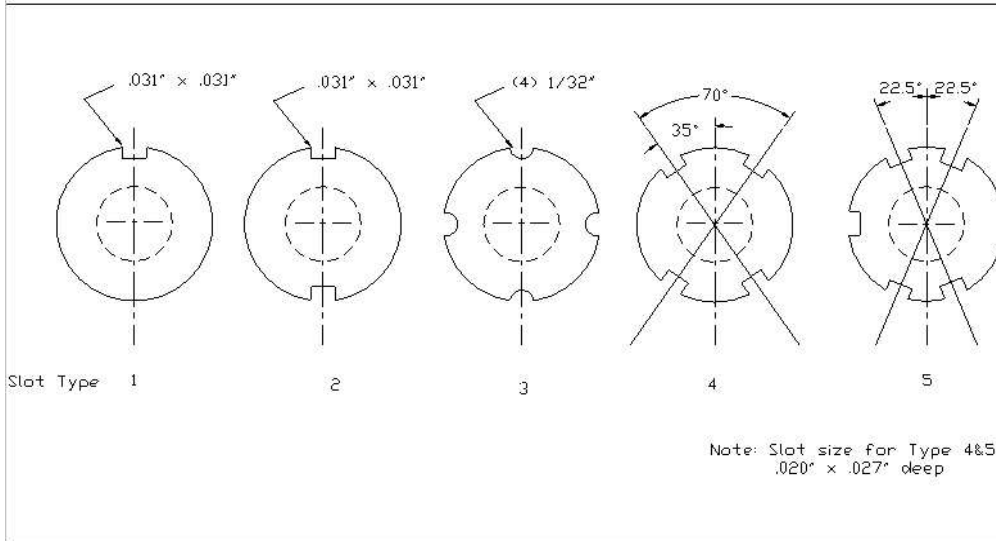

Part Number	Material	L/ 100 turns mH	D		L		W		S		Nominal Winding Area in.2 mm2	Average Turn Length ft. cm
			in. mm	in. mm	in. mm	in. mm	in. mm	in. mm				
P2-1491	E	1	0.312 7.92	0.25 6.35	0.125 3.18	0.14 3.56	0.01075 6.911	0.0592 1.803				
P2-1031	E	1	0.375	0.281	0.157	0.187	0.01476	0.0736				
P2-2783	C		9.52	7.14	3.99	4.75	9.516	2.241				
P2-2197	35	2	0.16 4.06	0.16 4.06	0.09 2.29	0.076 1.93	0.00378 2.439	0.0309 0.941				
P2-1092	E	2	0.25	0.187	0.062	0.093	0.00487	0.0449				
P2-1160	SF		6.35	4.75	1.57	2.36	3.132	1.368				
P2-1714	E	2	0.5 12.7	0.343 8.71	0.187 4.75	0.285 7.24	0.0201 12.967	0.1027 3.132				
P2-2607	E	3	0.25 6.35	0.187 4.75	0.093 2.36	0.093 2.36	0.0073 4.708	0.0449 1.368				
P2-1022	E	4	0.25	0.187	0.062	0.093	0.00487	0.0449				
P2-2694	TH		6.35	4.75	1.57	2.36	3.132	1.368				
P2-1173	SF											
P2-2695	TH	4	0.25	0.187	0.062	0.155	0.00294	0.053				
P2-2696	PY11B		6.35	4.75	1.57	3.94	1.892	1.616				
P2-2278	TH	5	0.25 6.35	0.187 4.75	0.062 1.57	0.093 2.36	0.00487 3.132	0.0449 1.368				
P2-2102	TH	5	0.25 6.35	0.187 4.75	0.062 1.57	0.12 3.05	0.00403 2.59	0.0484 1.476				
P2-1791	E	5	0.25 6.35	0.187 4.75	0.094 2.39	0.093 2.36	0.00738 4.768	0.0449 1.368				
P2-1667	SF	5	0.25 6.35	0.187 4.75	0.094 2.39	0.095 2.41	0.00728 4.708	0.0452 1.376				
P2-1668	SF	5	0.25 6.35	0.187 4.75	0.094 2.39	0.099 2.51	0.0071 4.589	0.0457 1.392				
P2-1669	SF	5	0.25 6.35	0.187 4.75	0.094 2.39	0.104 2.64	0.00686 4.433	0.0463 1.412				
P2-1670	SF	5	0.25 6.35	0.187 4.75	0.094 2.39	0.109 2.77	0.00663 4.278	0.047 1.432				
P2-2217	E	5	0.25	0.187	0.09	0.145	0.00472	0.0517				
P2-2218	TH		6.35	4.75	2.29	3.68	3.057	1.575				
P2-2216	C											

TSC bourgeois

GENERAL DATA ON LAMINATIONS

For standard type laminations, the following pages contain information on the types of materials available, their mechanical and physical characteristics, and their electrical and magnetic properties.

Types of Material

TSC-Arnold Technologies' laminations are made from various grades of electrical steels, silicon steels, nickel-iron alloys, and cold rolled motor lamination steel.

Electrical & Silicon Steels

Laminations made from various grades of electrical silicon steels are the most economical for use in small transformers and reactors. These steels are classified according to ASTM A664.

Grain Oriented

TSC-Arnold Technologies provides grain-oriented laminations in thickness of .006 and .014 (29 gauge) inches. This material shows very low core losses and high permeability in the rolling direction. Laminations made from this material are supplied in a fully stress relief annealed condition with high interlaminar resistance and a high stacking factor.

Non-Oriented

TSC-Arnold Technologies provides various grades of non-oriented silicon steels. The most common thicknesses are .0185 (26 gauge) and .025 (24 gauge) inches. Silicon content for these types of steels influences the core loss characteristics. Steels with higher silicon contents typically have lower core losses. Laminations made from these grades of steels are supplied in a fully stress relief annealed condition with high interlaminar resistance and high stacking factors.

Cold Rolled Motor Lamination Steel

TSC-Arnold Technologies provides cold rolled motor lamination steel in thickness of .018 (26 gauge) and .025 (24 gauge). Laminations produced from cold rolled motor lamination steel are used in fractional motors and transformers where low core losses are not critical and better permeability at a high KG is desired. Laminations made from this material are supplied in a fully stress relief annealed condition.

Nickel-Iron Alloys

Laminations produced from both low nickel iron alloys (50% nickel) and high nickel iron alloys (80% nickel) are used where both high performance and compactness are essential.

High Nickel-Iron Alloys (80% Nickel)

TSC-Arnold Technologies provides high nickel alloys in thickness of .006" and .014" (29 gauge). This material has very high initial and maximum permeability for use in low density, high frequency applications, including telecommunications, ground fault interrupters and magnetic shielding. Laminations made from this material are supplied in a fully annealed condition, for highest permeability or lowest total harmonic distortion, with an inorganic coating for an optimum stacking factor. The thickness and the designation HN is used as a suffix after the lamination shape to form the catalog part number. *For example: EI375-0140-HN.*

Low Nickel-Iron Alloys (50% Nickel)

TSC-Arnold Technologies provides low nickel alloys in thickness of .006" and .014" (29 gauge). This material shows high initial and maximum permeability for use in moderately low flux density applications, such as: servomotors, relay, armatures, and solenoids. Laminations made from this material are supplied in a fully annealed condition, assuring high permeability, with an inorganic coating for an optimum stacking factor. The thickness and the designation LN is used as a suffix after the lamination shape to form the catalog part number. *For example: EI375-0140-LN.*

TSC bourgeois

MECHANICAL AND PHYSICAL CHARACTERISTICS

TSC-Arnold Technologies' lamination standards for all applicable mechanical and physical characteristics meet or exceed the recognized industry standards. The most important of these are:

Tolerances

By maintaining the below listed tolerances, TSC-Arnold Technologies' laminations have a mechanical consistency that ensures good stacking characteristics and low gap losses.

Gauge No.	Gauge Thickness	Gauge Tolerance + or -	Burr Tolerance Max	Dimension Tolerances + or -	Flatness* Tolerances
29	.0140	.001	.0020**	.005	.022
26	.0185	.002	.0025	.005	.028
24	.0250	.003	.0030	.005	.035

* 1½" center leg and under measured with a bridge type gauge

** Nickel is .0010

Surface Insulation

The normal surface oxide on both silicon and nickel flat rolled steels provides some degree of interlamination resistance, which may be adequate for many applications. However, as additional interlamination resistance is generally desired, TSC-Arnold Technologies' laminations are coated with one of the following inorganic coatings:

Material	Coating Type	AISI Type
Grain Oriented	C-10	C-4
Non-Oriented	C-5	C-5
Nickel (High & Low)	Magnesium Oxide <i>or</i> Magnesium Methyllate (Type 2)	- -

Packaging

Various methods of packaging, depending on the part number, are used for the maximum protection of the laminations in transit. Regardless of the method employed, all have the following standards:

- ❖ E and I laminations must be packed together as stamped to insure equal thickness and quantities.
- ❖ The thickness variation between E and I laminations in any one carton cannot exceed $\pm 2\%$.
- ❖ A layer of rust inhibiting paper (V.C.I. or equivalent) shall be packed between lamination layers.

TSC bourgeois

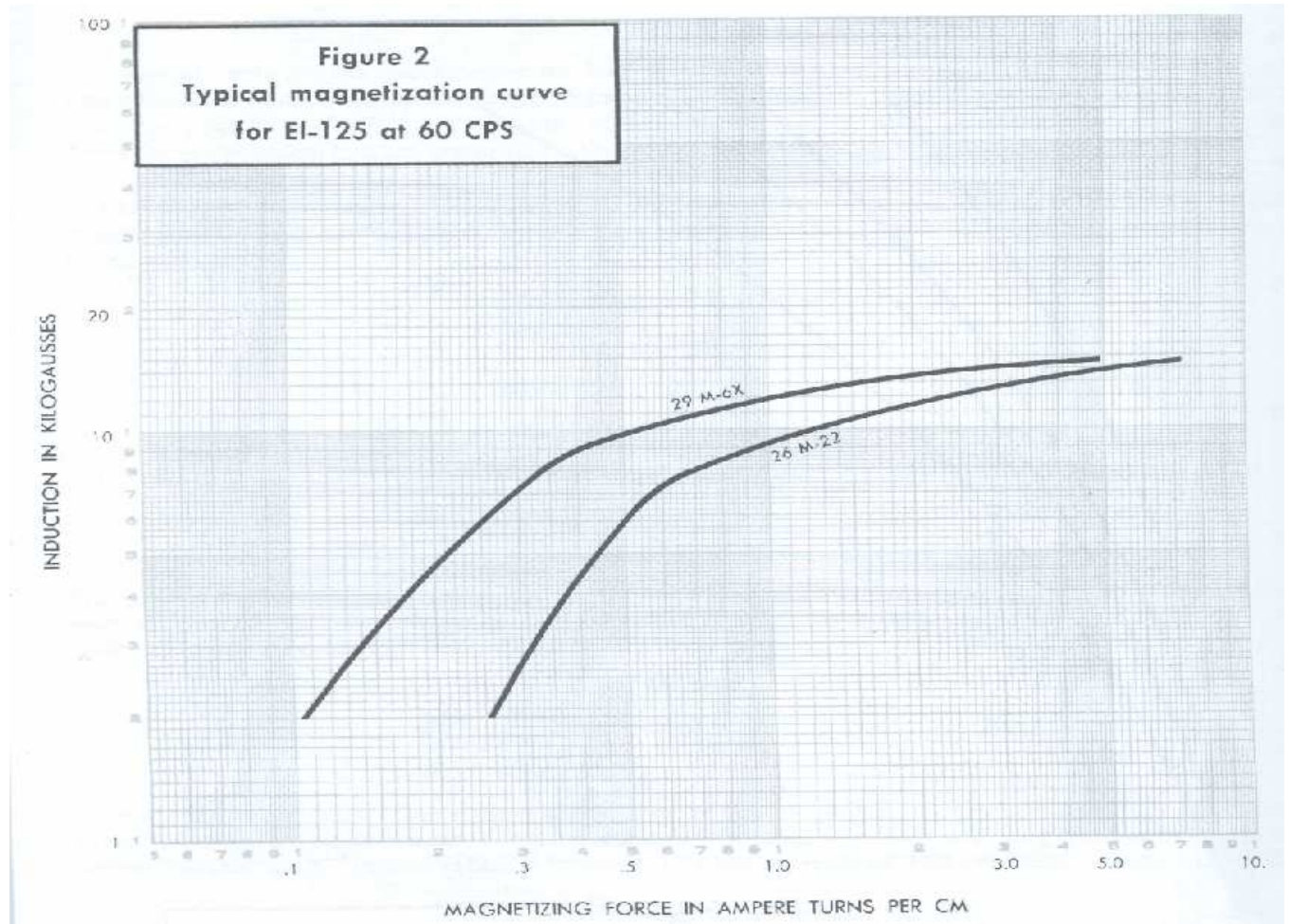
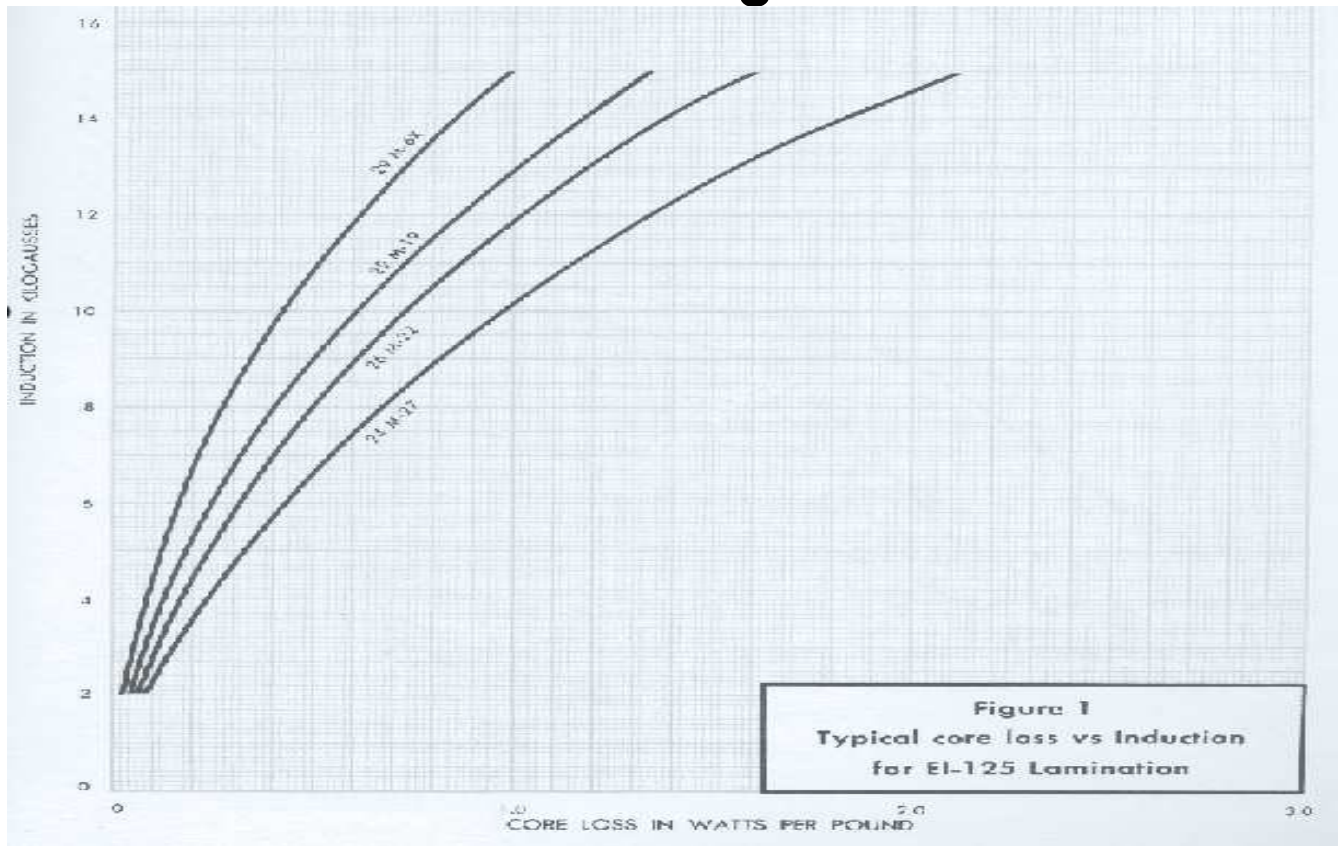

TSC bourgeois

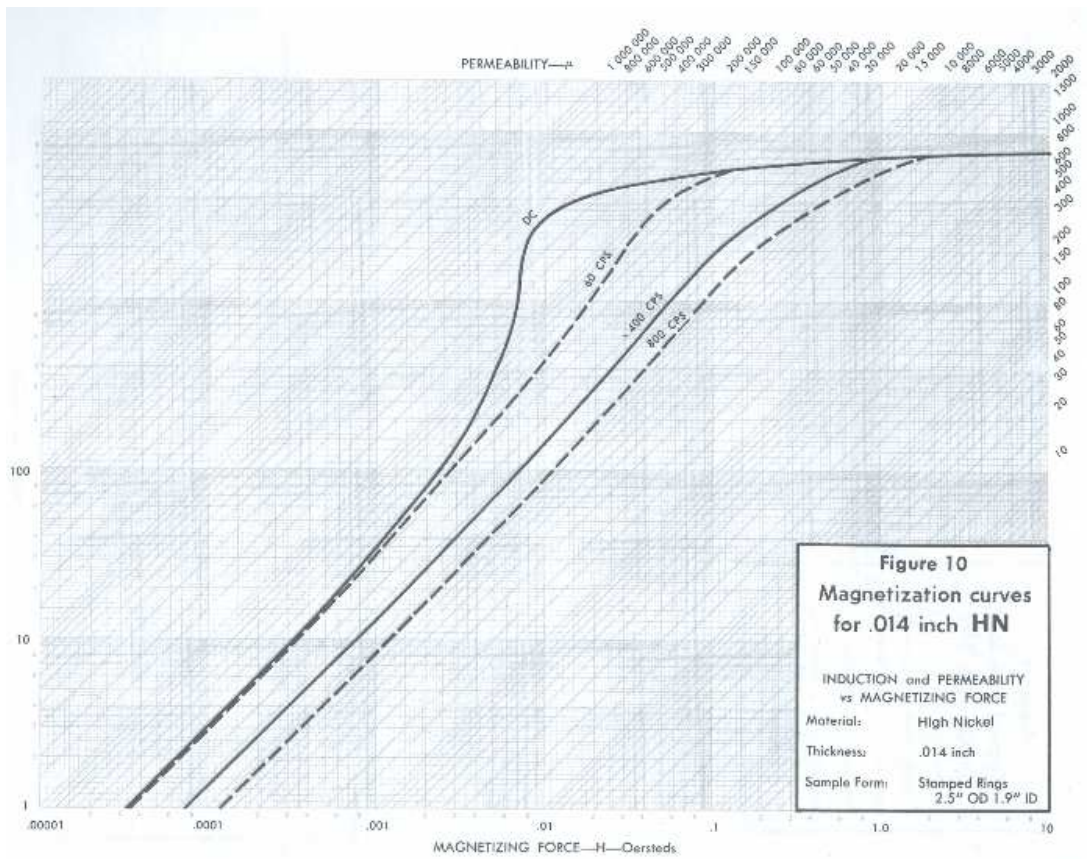
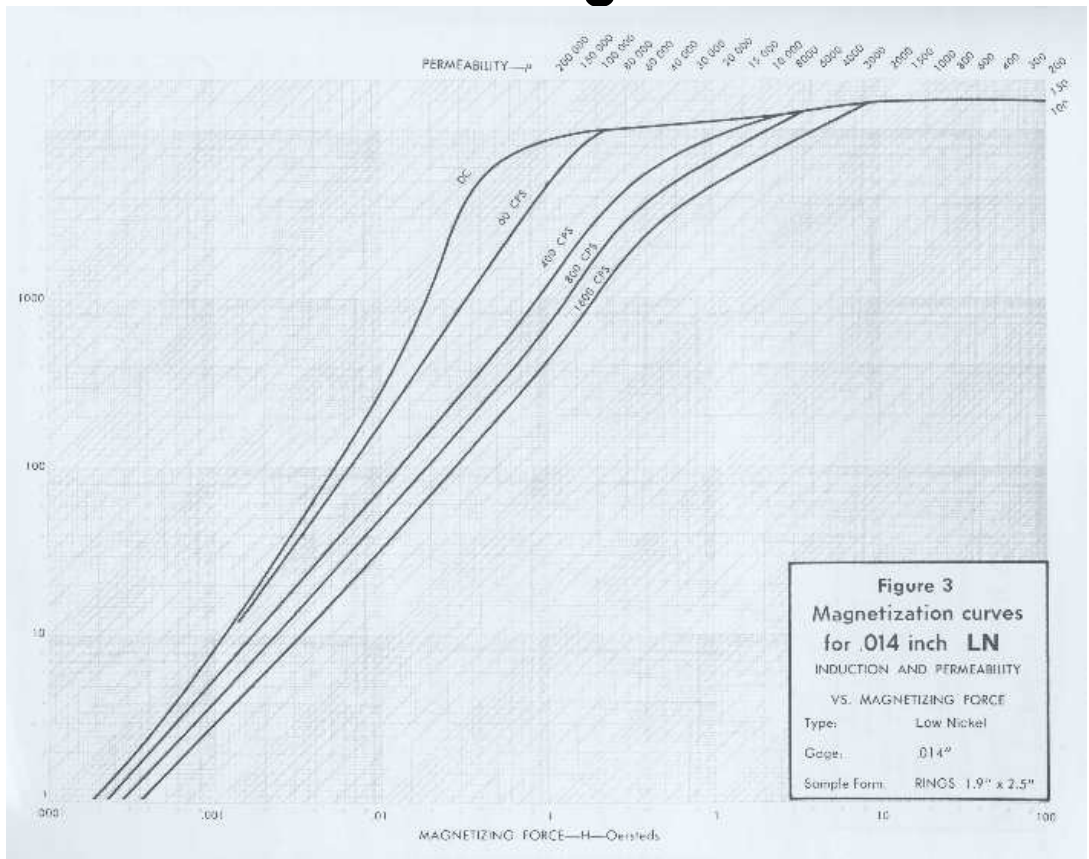

TSC bourgeois

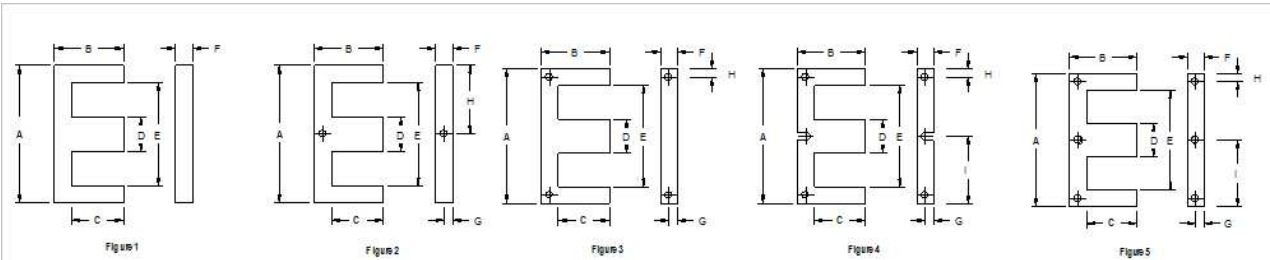

TSC-ARNOLD TECHNOLOGIES EI LAMINATION DIMENSIONS

	PART #	FIGURE	A in	B in	C in	D in	E in	F in	G in	H in	Hole in
	EI094	1	0.375	0.203	0.156	0.094	0.281	0.047			
	EI186	1	0.750	0.344	0.250	0.188	0.563	0.094			
	EI187	1	0.750	0.531	0.438	0.188	0.563	0.094			
3/8	EI375	2	1.375	0.938	0.750	0.375	1.000	0.188	0.094	0.688	0.089
	EI21	2	1.625	1.063	0.813	0.500	1.125	0.250	0.125	0.750	0.125
1/2	EI50	2	1.500	1.000	0.750	0.500	1.000	0.250	0.125	0.750	0.125
5/8	EI625	2	1.875	1.250	0.938	0.625	1.250	0.313	0.156	0.938	0.125
3/4	EI75	2	2.250	1.500	1.125	0.750	1.500	0.375	0.188	1.125	0.125
7/8	EI87	3	2.625	1.750	1.313	0.875	1.750	0.438	0.219	0.219	0.187
1	EI100	3	3.000	2.000	1.500	1.000	2.000	0.500	0.250	0.250	0.218
1 1/8	EI112	3	3.375	2.250	1.688	1.125	2.250	0.563	0.281	0.281	0.218
1 1/4	EI125	3	3.750	2.500	1.875	1.250	2.500	0.625	0.313	0.313	0.218
	EI125R*	4	3.750	2.500	1.875	1.250	2.500	0.625	0.219	0.219	0.218
1 3/8	EI138	3	4.125	2.750	2.063	1.375	2.750	0.688	0.344	0.344	0.218
1 1/2	EI150*	4	4.500	3.000	2.250	1.500	3.000	0.750	0.375	0.375	0.218
1 3/4	EI175	3	5.250	3.500	2.625	1.750	3.500	0.875	0.438	0.438	0.281
2	EI200R	5	7.500	5.000	3.750	2.000	5.000	1.250	0.375	0.375	0.391
	EI200SR	3	6.000	4.000	3.000	2.000	4.000	1.000	0.313	0.313	0.313
2 1/8	EI212	3	6.375	4.250	3.188	2.125	4.250	1.063	0.531	0.531	0.328
2 1/4	EI225R	3	6.750	4.500	3.375	2.250	4.500	1.125	0.313	0.313	0.313
2 1/5	EI250R	5	7.500	5.000	3.750	2.500	5.000	1.250	0.375	0.375	0.391
	EI251R	5	9.000	6.750	5.500	2.500	6.500	1.250	0.500	0.500	0.375
3	EI300R	5	9.000	6.000	4.500	3.000	6.000	1.500	0.375	0.375	0.375
4	EI400R	5	12.000	8.000	6.000	4.000	8.000	2.000	0.438	0.438	0.406
1 1/4	EI1250FR	5	4.438	4.375	3.688	1.250	3.063	0.688	0.344	0.344	0.210
1 3/8	EI4731FR*	4	5.250	3.500	2.625	1.375	3.500	0.875	0.438	0.438	0.281
	EI5731FR*	4	5.250	4.875	4.000	1.375	3.500	0.875	0.438	0.438	0.281
1 5/8	EI1625FR	5	5.750	5.313	4.375	1.625	3.875	0.938	0.469	0.469	0.281
2 1/8	EI2125FR	5	7.125	6.750	5.563	2.125	4.750	1.188	0.594	0.594	0.281
2 5/8	EI2625FR	5	8.688	8.219	6.750	2.625	5.750	1.469	0.734	0.734	0.313
3 1/4	EI3250FR	5	10.625	9.938	8.125	3.250	7.000	1.813	0.906	0.906	0.438
1 1/2	EI3P150	5	7.500	5.250	3.750	1.500	4.500	1.500	0.750	0.750	0.344
	EI3P180	5	9.000	6.300	4.500	1.800	5.400	1.800	0.900	0.900	0.344
	EI3P240	5	12.000	8.400	6.000	2.400	7.200	2.400	1.200	1.200	0.406
	EI3P360	5	18.000	12.600	9.000	3.600	10.800	3.600	1.800	1.800	0.547

TSC bourgeois

TSC-ARNOLD TECHNOLOGIES EI LAMINATION SQUARE STACK EFFECTIVE CORE SET PARAM												
	PART #	PATH	CORE	CORE	WINDOW	IN (80% Nickel)		N (49% Nickel)		Silicon		
		LENGTH	AREA	VOLUME	AREA	0.006	0.014	0.006	0.014	0.014	0.0185	0.025
		Le	Ae	Ve	Wa	Lbs/	Lbs/	Lbs/	Lbs/	Lbs/	Lbs/	Lbs/
		cm	cm^2	cm^3	in^2	Mprs	Mprs	Mprs	Mprs	Mprs	Mprs	Mprs
	EI094	1.64	0.06	0.09	0.09	0.122	0.285	0.115	0.268	0.250	---	---
	EI186	2.97	0.23	0.68	0.30	0.441	1.030	0.419	0.978	0.903	---	---
	EI187	3.93	0.23	0.89	0.53	0.573	1.338	0.541	1.262	1.165	---	---
3/8	EI375	6.90	0.91	6.26	1.51	2.020	4.710	1.910	4.450	4.110	5.420	7.330
	EI21	7.71	1.61	12.44	1.64	3.020	7.060	2.860	6.670	6.170	8.150	10.580
1/2	EI50	7.08	1.61	11.41	1.21	2.810	6.550	2.650	6.170	5.720	7.560	9.800
5/8	EI625	8.85	2.52	22.29	1.89	4.410	10.270	4.160	9.700	8.970	11.850	16.020
3/4	EI75	10.61	3.63	38.51	2.72	6.340	14.800	5.980	13.970	13.000	17.200	23.200
7/8	EI87	12.38	4.94	61.17	3.71	---	19.850	---	18.750	17.350	22.900	31.000
1	EI100	14.15	6.45	91.29	4.84	---	25.800	---	24.400	22.600	29.900	40.300
1 1/8	EI112	15.92	8.17	130.00	6.12	---	32.800	---	31.000	28.700	37.900	51.200
1 1/4	EI125	17.69	10.08	178.30	7.56	---	40.800	---	38.400	35.600	47.100	63.600
	EI125R*	17.69	10.08	178.30	7.56	---	40.800	---	38.400	35.600	47.100	63.600
1 3/8	EI138	19.46	12.20	237.35	9.15	---	---	---	---	43.200	57.200	77.200
1 1/2	EI150*	21.23	14.52	308.10	10.89	---	---	---	---	51.600	68.200	92.200
1 3/4	EI175	24.76	19.76	489.25	14.82	---	---	---	---	69.300	91.500	123.800
2	EI200R	35.79	29.58	1,058.67	36.29	---	---	---	---	126.300	166.800	---
	EI200SR	28.30	25.81	730.31	19.36	---	---	---	---	88.500	118.800	---
2 1/8	EI212	27.80	32.48	902.98	11.57	---	---	---	---	96.900	130.600	---
2 1/4	EI225R	31.84	32.66	1,039.84	24.50	---	---	---	---	108.800	146.700	---
2 1/5	EI250R	35.38	40.32	1,426.39	30.24	---	---	---	---	133.100	179.500	---
	EI251R	48.08	40.32	1,938.49	70.97	---	---	---	---	178.600	240.600	---
3	EI300R	42.45	58.06	2,464.80	43.55	---	---	---	---	193.100	260.300	---
4	EI400R	56.60	103.23	5,842.50	77.42	---	---	---	---	344.700	455.200	---
1 1/4	EI1250FR	28.65	10.67	305.71	21.57	---	---	---	---	17.380	---	---
1 3/8	EI4731FR*	25.05	14.12	353.71	17.99	---	---	---	---	61.520	---	---
	EI5731FR*	31.92	13.97	445.93	27.42	---	---	---	---	77.090	---	---
1 5/8	EI1625FR	35.02	18.54	649.31	31.75	---	---	---	---	93.110	---	---
2 1/8	EI2125FR	44.04	31.13	1,370.78	47.11	---	---	---	---	163.000	---	---
2 5/8	EI2625FR	53.49	47.53	2,542.74	68.04	---	---	---	---	226.640	---	---
3 1/4	EI3250FR	64.73	72.73	4,707.80	98.29	---	---	---	---	338.370	---	---
1 1/2	EI3P150	33.52	20.20	677.22	36.29	---	---	---	---	140.520	---	---
	EI3P180	40.22	29.09	1,170.24	52.26	---	---	---	---	203.240	---	---
	EI3P240	53.63	51.72	2,773.90	92.90	---	---	---	---	362.080	488.110	---
	EI3P360	80.45	116.38	9,361.90	209.03	---	---	---	---	815.910	---	---

Other material thicknesses and ASTM grades available upon request

TSC bourgeois

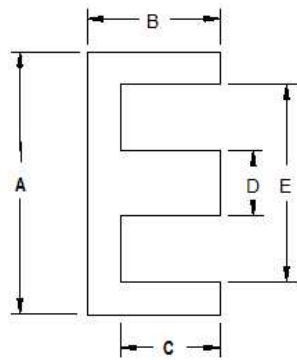

Figure 1

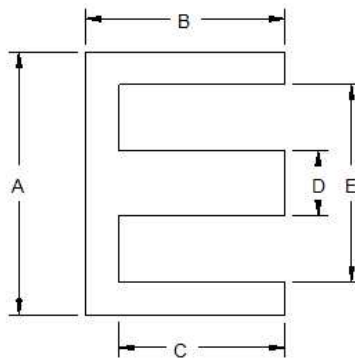

Figure 2

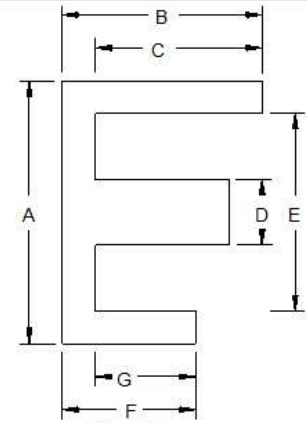

Figure 3

TSC-ARNOLD TECHNOLOGIES E & LE LAMINATION DIMENSIONS

	PART #	FIGURE	A	B	C	D	E	F	G	H
			in	in	in	in	in	in	in	in
	E250	1	0.840	0.445	0.320	0.250	0.590			
	E23	1	1.000	0.625	0.500	0.250	0.750			
	LE32	2	0.600	0.425	0.350	0.150	0.450			
16ELM	LE189	2	0.625	0.625	0.531	0.188	0.438			
186EL	EL186	1	0.750	0.438	0.344	0.188	0.563			
	LE186	2	0.780	1.078	0.883	0.195	0.585			
	LE187	3	0.750	0.625	0.531	0.188	0.563	0.438	0.344	0.438
2425EL	LE25	2	1.000	0.750	0.625	0.250	0.750			
	LE10	3	1.875	1.250	0.938	0.625	1.250	0.563	0.250	0.594
	LE625	1	2.500	1.563	1.250	0.625	1.875			

TSC-ARNOLD TECHNOLOGIES EE LAMINATION SQUARE STACK EFFECTIVE CORE SET PARAMETERS

NS	PART #	PATH LENGTH	CORE AREA	CORE VOLUME	WINDOW AREA	LN (80% Nickel)			LN (49% Nickel)			Silicon		
						0.006	0.014	0.006	0.014	0.014	0.0185	0.025		
						Lbs/Mprs	Lbs/Mprs	Lbs/Mprs	Lbs/Mprs	Lbs/Mprs	Lbs/Mprs	Lbs/Mprs		
	E250	5.112	0.403	2.061	0.054	0.502	1.172	0.474	1.106	---	---	---		
	E23	6.990	0.403	1.536	0.125	---	1.668	---	1.570	---	---	---		
	LE32	2.920	0.145	0.452	0.041	0.284	0.663	0.625	0.268	---	---	---		
16ELM	LE189	3.592	0.174	0.624	0.219	0.496	1.158	0.468	1.092	---	---	---		
186EL	EL186	3.180	0.227	0.721	0.047	0.367	0.824	0.346	0.808	---	---	---		
	LE186	5.960	0.246	1.835	0.865	---	2.190	---	2.070	---	---	---		
	LE187	6.350	0.226	1.440	0.164	0.447	1.039	0.421	0.979	0.921	---	---		
2425EL	LE25	5.080	0.403	2.050	0.125	0.830	1.936	0.782	1.825	1.593	---	---		
	LE10	10.800	2.520	27.000	0.371	---	5.840	---	5.530	5.100	---	---		
	LE625	11.113	2.600	24.000	0.524	---	10.450	---	9.860	---	---	---		

Other material thicknesses and ASTM grades available upon request

TSC bourgeois

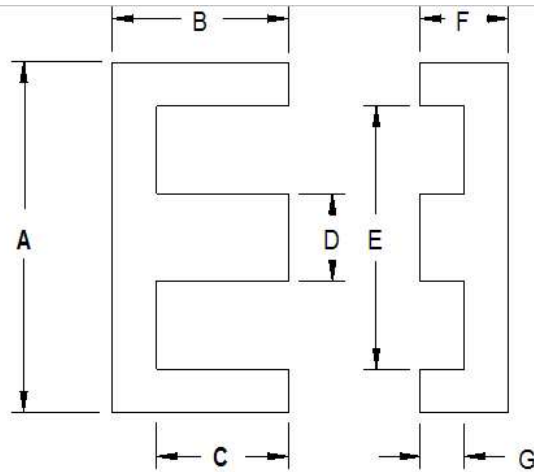

TSC-ARNOLD TECHNOLOGIES EE LAMINATION DIMENSIONS

	PART #	A in	B in	C in	D in	E in	F in	G in
3/32	EE3031	0.375	0.219	0.172	0.093	0.281	0.156	0.109
1/8	EE2829	0.500	0.313	0.250	0.125	0.375	0.125	0.063
	EE3233	0.580	0.270	0.200	0.140	0.440	0.145	0.075
3/16	EE186187	0.750	0.531	0.438	0.188	0.563	0.344	0.250
1/4	EE2425	1.000	0.500	0.375	0.250	0.750	0.250	0.125
3/8	EE2627	1.250	0.688	0.500	0.375	0.875	0.375	0.188
	EE2638	1.250	0.520	0.333	0.375	0.875	0.375	0.188
	EE2738	1.250	0.688	0.500	0.375	0.875	0.520	0.333

TSC-ARNOLD TECHNOLOGIES EE LAMINATION SQUARE STACK EFFECTIVE CORE SET PARAMET

PART #	PATH LENGTH Le cm	CORE AREA Ae cm ²	CORE VOLUME Ve cm ³	WINDOW AREA Wa in ²	IN (80% Nickel)			LN (49% Nickel)			Silicon	
					0.006 Lbs/ Mprs	0.014 Lbs/ Mprs	0.006 Lbs/ Mprs	0.014 Lbs/ Mprs	0.014 Lbs/ Mprs	0.0185 Lbs/ Mprs	0.025 Lbs/ Mprs	
EE3031	2.28	0.06	0.13	0.17	0.166	0.387	0.157	0.366	0.339	---	---	
EE2829	2.72	0.10	0.28	0.25	0.267	0.624	0.251	0.585	0.546	---	---	
EE3233	2.72	0.13	0.34	0.27	0.298	0.699	0.281	0.660	0.603	---	---	
EE186187	5.20	0.23	1.18	0.83	0.756	1.765	0.713	1.665	1.546	---	---	
EE2425	4.92	0.52	2.54	0.81	0.415	2.210	0.894	2.090	1.940	---	---	
EE2627	6.26	0.91	5.68	1.11	1.860	4.350	1.760	4.110	3.810	---	---	
EE2638	5.41	0.91	4.90	0.84	1.620	---	1.530	---	---	---	---	
EE2738	7.00	0.91	6.35	1.34	2.450	---	2.310	---	---	---	---	

Other material thicknesses and ASTM grades available upon request

TSC International

CORE SIZE SELECTION FOR POWER TRANSFORMERS

A Power Transformers Core selection is dependent on the amount of power the core will need to handle. A relationship between apparent Power (Pt) and Area Product (WaAe) can be derived from Faraday's Law as follows:

$$\text{Faraday's Law } N_p = \frac{V_p \times 10^4}{K_f B_m A_e f} \qquad N_s = \frac{V_s \times 10^4}{K_f B_m A_e f}$$

$$\text{Winding Area Utilization } K_u W_a = N_p A_{wp} + N_s A_{ws} \text{ (by definition } A_w = \frac{l}{J} \text{)}$$

$$\text{Substituting } \frac{l}{J} \text{ for } A_w \qquad K_u W_a = N_p \frac{l_p}{J} + N_s \frac{l_s}{J}$$

$$\text{Substituting } \frac{V \times 10^4}{K_f B_m A_e f} \text{ for } N_p \text{ and } N_s$$

$$K_u W_a = \left(\frac{V_p \times 10^4}{K_f B_m A_e f} \right) \left(\frac{l_p}{J} \right) + \left(\frac{V_s \times 10^4}{K_f B_m A_e f} \right) \left(\frac{l_s}{J} \right)$$

$$\text{Rearranging } W_a A_e = \frac{[(V_p l_p) + (V_s l_s)] 10^4}{K_u K_f B_m f J}$$

$$\text{Input Power } P_{in} = V_p I_p = \frac{V_s I_s}{\eta} = \frac{P_o}{\eta}$$

$$\text{Output Power} = P_o = V_s I_s$$

$$\text{Apparent Power} = P_t = P_{in} + P_o = \frac{P_o}{\eta} + P_o = P_o \left(\frac{1}{\eta} + 1 \right) = (V_p I_p + V_s I_s)$$

$$\text{Substituting } A_p = W_a A_e = \frac{P_t \times 10^4}{K_u K_e B f J}$$

- J = Current density (A/cm²)
- Ke = Wave Form Coefficient (typically 4 for square wave)
- Ku = Window Utilization Factor (typically 0.4)
- Wa = Window Area (winding area cm²)
- Np = Primary Turns
- Ns = Secondary Turns
- Ip = Primary Current in amperes
- Is = Secondary Current in amperes
- Vp = Primary Voltage
- Vs = Secondary Voltage
- Pt = Apparent Power (watts)
- Po = Output Power (watts)
- Pin = Input Power (watts)
- η = Efficiency
- Ae = Effective core cross sectional area in cm²
- B = Maximum Operating Flux density in tesla
- f = Frequency in Hz

WaAe is published for each of our cores in cm⁴

TSC International

$B = \frac{E_{rms} \times 10^8}{4.44FN\mu_e}$ IN GAUSS (FOR A SINE WAVE CONDITION)	$\mu = \frac{B}{H}$
$B = \frac{E_{avg} \times 10^8}{4FN\mu_e}$ IN GAUSS (FOR A SQUARE WAVE CONDITION)	$L = \frac{.004 \pi N^2 A_e \times 10^{-9} \mu}{L_e}$ IN HENRIES
$B = \frac{E_{PEAK} \times 10^8 t}{NA_e}$ IN GAUSS (FOR A PULSED WAVE CONDITION)	$L_{air} = \frac{.004 \pi A_e \times 10^{-9}}{L_e}$ IN HENRIES/N ²
$H_{ac} = \frac{0.4 \pi N \sqrt{2} I_{rms}}{L_e}$ IN OERSTEDS	$A_L = \mu_e L_{air} \times 10^9$ IN NANO HENRIES/N ²
$H_{dc} = \frac{0.4 \pi NI_{dc}}{L_e}$ IN OERSTEDS	$Q = \frac{X_L s}{R_s} \text{ or } \frac{2 \pi FL_s}{R_s}$

Determine approximate A_L from known gap: **OR** determine approximate gap from known A_L :

$$A_L = \frac{4 \pi \mu A_e A_g}{\mu A_e L_g + A_g(L_e - L_g)}$$

$$L_g = \left(\frac{4 \pi \mu A_e A_g}{A_L} - A_g L_e \right) \div (\mu A_e - A_g)$$

A_L = Inductance index in nH/N² or mH/1000 turns
 μ = Material permeability
 A_e = Effective cross sectional area in CM²
 A_g = Area of gap in CM²
 L_e = Effective magnetic path length in CM
 L_g = Gap length in CM
 G = Winding length in CM

Formulas neglect fringing flux. Multiply the equation for A_L value by $(1 + L_g/\sqrt{A_e} \ln(2G/L_g))$ to account for fringing flux.

REFERENCES

Annual book for ASTM Standards Volume 03.04
 Metals Test Methods and Analytical Procedures for Magnetic Properties...

Available from: American Society for Testing and Materials
 100 Barr Harbor Drive
 West Conshohocken, PA 19428-2959
 Phone: (610) 832-9500

IMA Publications on Soft Ferrites
 Soft Ferrites A User's Guide
 Standard No. UEI 310 Standard Specifications for Ferrite U,E&I cores
 Standard No. PC 110 Standard Specifications for Ferrite Pot Cores
 Standard No. FTC 410 Standard Specifications for Ferrite Toroid Cores
 Permanent Magnet Guidelines
 Standard No. 0100-90 Standard Specifications for Permanent Magnet Materials

Available from: International Magnetics Association
 8 South Michigan Avenue, Suite 1000
 Chicago, IL 60603
 Phone: (312) 456-5590
 FAX: (312) 580-0165

TSC International

GLOSSARY OF TERMS

SYMBOL	UNIT	DEFINITION
H	OERSTED	MAGNETIC FIELD STRENGTH (MAGNETIZING FORCE) The externally applied magnetizing force that induces magnetic flux in a magnetic material.
H _s	OERSTED	SATURATION MAGNETIZATION FORCE The value of magnetizing force (H) required to achieve saturation.
H _c	OERSTED	COERCIVE FORCE The magnetizing force required to reduce the magnetic induction in a magnetic structure from B _r to zero.
B	GAUSS	MAGNETIC FLUX DENSITY (MAGNETIC INDUCTION) The flux per unit area induced by a field strength (H).
B _s	GAUSS	SATURATION FLUX DENSITY The value of magnetic flux density at saturation. It is material's maximum magnetic induction possible.
B _r	GAUSS	RESIDUAL INDUCTION (REMANENCE) The magnetic induction (B) remaining in a magnetized material after the magnetizing force (H) has been reduced to zero.
μ	—	PERMEABILITY The measure of a material's ability to conduct magnetic flux relative to air (where air is assumed to have a permeability of one (1)). The ratio of the flux (B) in a material that results from a known magnetizing force (H) divided by that same known magnetizing force (H) ($\mu = B/H$).
μ_i	—	INITIAL PERMEABILITY The relative permeability at very low magnetic field strengths (H).
μ_B	—	EFFECTIVE PERMEABILITY The relative permeability of a magnetic structure including the effect of air gaps in the magnetic path length.
μ_m	—	MAXIMUM PERMEABILITY The maximum value of permeability observed on a magnetic material as its normal magnetization curve is traversed.
L	HENRY	INDUCTANCE (INDUCTOR) Electrical circuit property that opposes any change in current because of a magnetic field.
AL	nH/N ² or mH/1000 TURNS	INDUCTANCE INDEX Inductance per unit turn.
Q	—	Q FACTOR A measure of the losses in a material at very low levels of magnetizing force. High Q means low losses; low Q means high losses.
TAN δ/μ	—	LOSS FACTOR Figure of merit of a material. Eddy current and residual losses per unit of permeability (1/100).
T.C.	%/°C or PPM/°C	TEMPERATURE COEFFICIENT The effect of temperature on magnetic characteristics, such as μ , B, H, etc. always expressed over a specified temperature range.
T _c	°C	CURIE TEMPERATURE The temperature at which a ferromagnetic material becomes paramagnetic. The temperature at which a material's initial permeability becomes equal to the permeability of air which is assumed to be one (1).
L _e	cm	EFFECTIVE MAGNETIC PATH LENGTH Normalized distance of the path that the magnetic flux takes through the core.
A _e	cm ²	EFFECTIVE CROSS SECTIONAL AREA Normalized core area perpendicular to the magnetic line of flux.

TSC International

GLOSSARY OF TERMS (continued)

SYMBOL	UNIT	DEFINITION
Ve	cm ³	EFFECTIVE CORE VOLUME Effective volume of the magnetic core material (may be less than the physical volume of the core).
Wa	cm ²	CORE WINDOW AREA Area available for windings.
WaAe	cm ⁴	POWER HANDLING CAPABILITY INDEX The product of a core's effective cross sectional area and its window area. Also known as area product (Ap).
—	—	SATURATION A magnetic material is saturated when increases in magnetizing force (H) no longer appreciably increase the magnetic induction (B).
—	mw/cm ³	CORE LOSS A measure of the efficiency of a material at relatively high levels of magnetizing force (H). Power dissipated in the material (analogous to IR loss in a resistor).
—	—	HYSTERESIS CURVE A curve showing the relationship between a magnetizing force (H) and the resultant magnetic induction (B).
—	—	TRANSFORMER A device that transforms electric energy from one circuit to another circuit by electromagnetic induction. The transformed electric energy is at the same frequency but often at different voltage and current values. Transformers are often used to step up or down voltage or current, match impedances or isolate one circuit from another.
—	—	CHOKE COIL (FILTER) Inductor placed in a circuit to "choke out" unwanted frequencies. Often used to allow direct current to pass while opposing pulsating or alternating current.
thd	decibels	TOTAL HARMONIC DISTORTION The ratio of output power at the fundamental frequency to the output power of all harmonics.

Prefix	Symbol	Factor
yocto	y	10 ⁻²⁴
zepto	z	10 ⁻²¹
atto	a	10 ⁻¹⁸
femto	f	10 ⁻¹⁵
pico	p	10 ⁻¹²
nano	n	10 ⁻⁹
micro	μ	10 ⁻⁶
milli	m	10 ⁻³
centi	c	10 ⁻²
deci	d	10 ⁻¹
deca	da	10 ¹
hecto	h	10 ²
kilo	k	10 ³
mega	M	10 ⁶
giga	G	10 ⁹
tera	T	10 ¹²
peta	P	10 ¹⁵
exa	E	10 ¹⁸
zetta	Z	10 ²¹
yotta	Y	10 ²⁴

TSC International

Metric System SI Units

Quantity	Metric Symbol	Metric SI Units	Customary Symbol	Customary Units	Multiplication Factor to Convert from Customary Units to SI Units
Area	m ²	Square meter	cm ²	Square centimeter	1x10 ⁻⁴
Celsius Temperature	°C	Degree Celsius	°F	Degree Fahrenheit	(F-32)*5/9
Density	kg/m ³	Kilogram per cubic meter	g/cm ³	Gram per cubic centimeter	1x10 ³
Electric resistance	Ω	Ohm	Ω	Ohm	1
Electrical charge	C	Coulomb	E.M.	Electric charge per mass	10
Electric current	A	Ampere	I	Ampere	1
Electrical potential, electromotive force	V	Volt	E	Volt	1
Energy, work	J	Joule	ERG	Centimeter-gram-second	1x10 ⁻⁷
Force	N	Newton	#	Pounds	4.44822
Frequency	Hz	Hertz	kHz	Kilohertz	1x10 ³
Inductance, Inductor	H	Henry	L	Henry	1
Length	m	Meter	cm	Centimeter	1x10 ⁻²
Magnetic field strength	A/m	Ampere per meter	Oe	Oersteds	79.58
Magnetic flux	Wb	Weber	Mx	Maxwell	1x10 ⁻⁸
Magnetic flux density, Magnetic Induction	T	Tesla	g	Gausses	1x10 ⁻⁴
Mass	kg	Kilogram	g	Gram	1x10 ⁻³
Permeability	H/m	Henry per meter	μ	(Unit less)	4x10 ⁻⁷
Power	W	Watt	W	Mw	1x10 ⁻³
Power Loss Density	kW/m ³	Kilowatt per cubic meter	Pc	mW/cm ³	1
Pressure, stress	Pa	Pascal	PSI	Lbs/in ²	6896.5
Thermal conductivity	W/(m*K)	Watt per meter Kelvin			
Time	S	Second	S	Second	1
Volume	m ³	Cubic meter	cm ³	Cubic centimeter	1x10 ⁻⁶

TSC International

CROSS REFERENCE OF TSC INTERNATIONAL PART NUMBERS

Part Type	Description	TSC FERRITE Int'l. PART # Soft Ferrite	TSC Pyroferic PART # Iron Powder	TSC Arnold Technologies PART # Lamination
E Core	EE2829	13-06-03		EE2829
E Core	EF12.6	13-06-04	PE51	
E Core	EF16	16-08-05	PE63	
E Core	E3233	17-07-03		EE3233
E Core	E187	19-08-05	PE75	EI186
E Core	EF 20	20-10-06	PE80	
E Core	E2425	25-10-06	PE100	EE2425
E Core		25-16-06		LE25
E Core	E30/7	30-15-07	PE118	
E Core	E375	34-14-09	PE137	EI375
E Core	E21	41-16-12	PE162	EI21
E Core	E42/15	42-21-15	PE168	
E Core	E42/20	42-21-20	PE168A	
E Core	E625	47-21-16		EI625
E Core	E75	56-24-19		EI75
E Core	EE65	70-54-32		EI87

Core Materials Performance Factor vs. Frequency

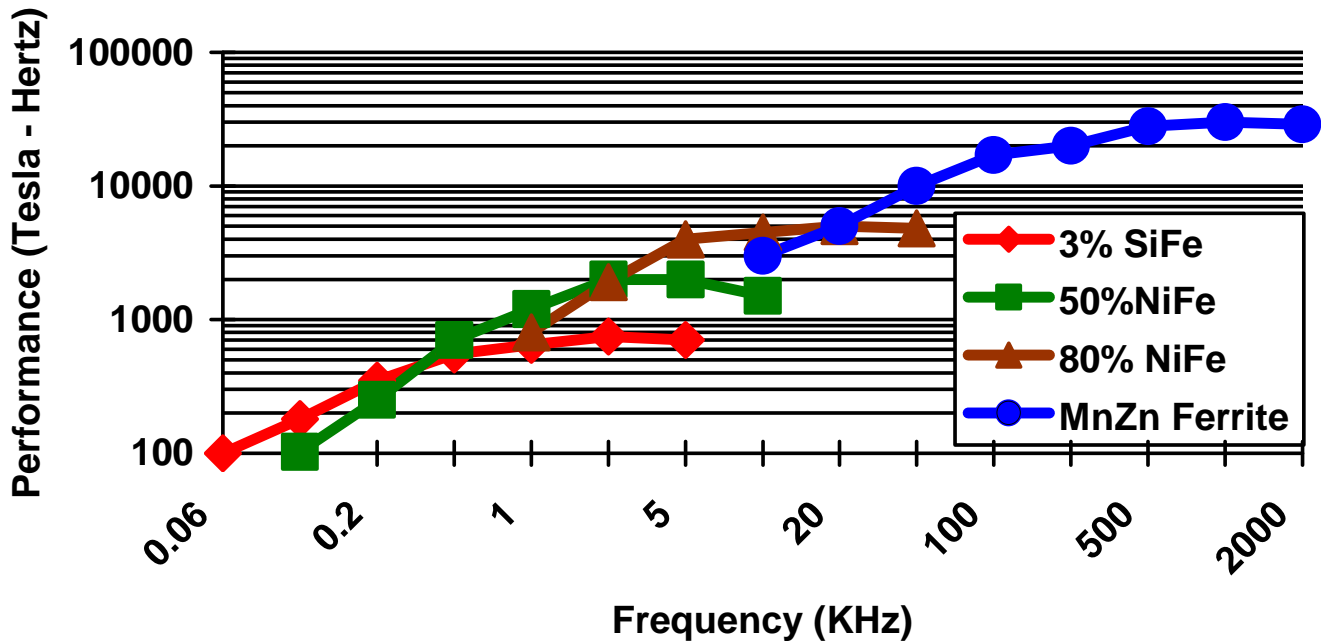

TSC International

FORMULAS FOR CALCULATING QUALITY METRICS

VARIABLE DATA

<i>METRIC</i>	<i>Double Sided</i>	<i>Single Sided with Upper Limit</i>	<i>Single Sided with Lower Limit</i>
Cp	$(USL-LSL)/6s$	$(USL-m)/3s$	$(m-LSL)/3s$
K	$ T-m /(USL-LSL)(0.5)$	$ T-M /(T-USL)$	$ T-m /(LSL-T)$
Cpk	$Cp(1-k)$	$Cp(1-k)$	$Cp(1-k)$
Sigma	3 Cpk	3Cpk	3Cpk

Where:

Cp	=	Centered process capability
k	=	Process mean offset
Cpk	=	Process capability
m	=	sample mean
s	=	sample standard deviation
USL	=	Upper spec limit
LSL	=	Lower spec limit
T	=	Target value

TSC INTERNATIONAL WARRANTIES AND DISCLAIMERS

"TSC International" expressly warrants to the "Buyer" for whom it manufactures, sells and delivers product made of magnetic materials will conform to specifications and drawings as published within the product catalog. Buyer specifications that have not been approved by the International Electronic Commission shall be considered as a custom product, and will be warranted by TSC International for the buyer in a separate written agreement.

There are no other express or implied warranties which extend beyond the above-referenced warranty of conformity to the specifications and specifically, TSC International does not warrant that any product will be merchantable or fit for the particular purpose for which the purchaser, its successors, agents, assigns or affiliates, intends to use such product.

Buyer shall notify TSC International in writing (and reasonable detail) of any defect in any product within thirty (30) days after the delivery date thereof. If products do not conform to the specification, buyer's remedy shall be limited, at TSC International's sole discretion, to either (1) The return of such product in exchange for the return of or credit for any payment received by TSC International relating thereto; (2) The replacement of such product; or (3) The repair of such product. TSC International shall pay for all reasonable shipping costs incurred in connection with the return, replacement or repair of any defective product. Solution to resolve defective product shall be within (60) days after receipt of written notice from buyer of such defect.

TSC International shall not be liable for any incidental or consequential loss, damage or expense (including without limitation, economic loss or lost profits) or buyer for any defective product sold and delivered to buyer regardless or whether such loss, damage or expense results from a breach of contract or warranty or commission of a tort (including, without limitation, strict liability or negligence).

TSC International

CONVERSION FOR QUALITY METRICS

Z	CPK	SIGMA	PROBABILITY OF		
			GOOD	DEFECT	PPM
1.5	0.50	3.0	93.3200%	6.6800%	66800
1.6	0.53	3.1	94.5200%	5.4800%	54800
1.7	0.57	3.2	95.5400%	4.4600%	44600
1.8	0.60	3.3	96.4100%	3.5900%	35900
1.9	0.63	3.4	97.1300%	2.8700%	28700
2.0	0.67	3.5	97.7200%	2.2800%	22800
2.1	0.70	3.6	98.2100%	1.7900%	17900
2.2	0.73	3.7	98.6100%	1.3900%	13900
2.3	0.77	3.8	98.9300%	1.0700%	10700
2.4	0.80	3.9	99.1800%	0.8200%	8200
2.5	0.83	4.0	99.3800%	0.6200%	6200
2.6	0.87	4.1	99.5300%	0.4700%	4700
2.7	0.90	4.2	99.6500%	0.3500%	3500
2.8	0.93	4.3	99.7400%	0.2600%	2600
2.9	0.97	4.4	99.8100%	0.1900%	1900
3.0	1.00	4.5	99.8700%	0.1300%	1300
3.1	1.03	4.6	99.9000%	0.1000%	1000
3.2	1.07	4.7	99.9300%	0.0700%	700
3.3	1.10	4.8	99.9500%	0.0500%	500
3.4	1.13	4.9	99.9700%	0.0300%	300
3.5	1.17	5.0	99.9767%	0.0233%	233
3.6	1.20	5.1	99.9841%	0.0159%	159
3.7	1.23	5.2	99.9892%	0.0108%	108
3.8	1.27	5.3	99.9928%	0.0072%	72
3.9	1.30	5.4	99.9952%	0.0048%	48
4.0	1.33	5.5	99.9968%	0.0032%	32
4.1	1.37	5.6	99.9979%	0.0021%	21
4.2	1.40	5.7	99.9987%	0.0013%	13
4.3	1.43	5.8	99.9992%	0.0009%	9
4.4	1.47	5.9	99.9995%	0.0005%	5
4.5	1.50	6.0	99.9997%	0.0003%	3

PROBABILITIES ASSUME LARGE SAMPLE SIZE, NORMAL DISTRIBUTION AND A HIGH CONFIDENCE LEVEL

INCH - TO - METRIC CONVERSIONS

FRACTIONS	INCHES		MILLI-METERS
	DECIMALS		
1/64	0.016	0.397	
1/32	0.031	0.794	
3/64	0.047	1.191	
1/16	0.062	1.588	
5/64	0.078	1.984	
3/32	0.094	2.381	
7/64	0.109	2.778	
1/8	0.125	3.175	
9/64	0.141	3.572	
5/32	0.156	3.969	
11/64	0.172	4.366	
3/16	0.188	4.763	
13/64	0.203	5.159	
7/32	0.219	5.556	
15/64	0.234	5.953	
1/4	0.250	6.350	
17/64	0.266	6.747	
9/32	0.281	7.144	
19/64	0.297	7.541	
5/16	0.312	7.938	
21/64	0.328	8.334	
11/32	0.344	8.731	
23/64	0.359	9.128	
3/8	0.375	9.525	
25/64	0.391	9.922	
13/32	0.406	10.318	
27/64	0.422	10.716	
7/16	0.438	11.113	
29/64	0.453	11.509	
15/32	0.469	11.906	
31/64	0.484	12.303	
1/2	0.500	12.700	
33/64	0.515	13.097	
17/32	0.531	13.494	
35/64	0.547	13.891	
9/16	0.562	14.288	
37/64	0.578	14.684	
19/32	0.594	15.081	
39/64	0.609	15.478	
5/8	0.625	15.875	
41/64	0.641	16.272	
21/32	0.656	16.669	
43/64	0.672	17.066	
11/16	0.688	17.463	
45/64	0.703	17.859	
23/32	0.719	18.256	
47/64	0.734	18.653	
3/4	0.750	19.050	
49/64	0.766	19.447	
25/32	0.781	19.844	
51/64	0.797	20.241	
13/16	0.812	20.638	
53/64	0.828	21.034	
27/32	0.844	21.431	
55/64	0.859	21.828	
7/8	0.875	22.225	
57/64	0.891	22.622	
29/32	0.906	23.019	
59/64	0.922	23.416	
15/16	0.938	23.813	
61/64	0.953	24.209	
31/32	0.969	24.606	
63/64	0.984	25.003	
1	1.000	25.400	



INTERNATIONAL

Ferrite International . Pyroferic . TSC Bourgeois

Top 10 Reasons to Source Ferrites & Iron Powder Cores from TSC Ferrite International

10. **Knowledgeable and dependable.** >72 years experience manufacturing iron powder cores. >20 years experience manufacturing ferrite cores. >14 year experience stamping laminations.
9. **Short supply chain and close proximity.** Buy direct from centrally located NAFTA manufacturer.
8. **One stop shopping.** Full product lines including all industry standard material grades, shapes & sizes for all your ferrite, iron powder core and lamination requirements.
7. **Innovative, revolutionary material grades** (Low loss, temperature stable "TSP-50ALL Flat Line" for transformers & high saturation "TSP-Boost" for inductors).
6. **Custom material, shape and size development capability.**
5. **TSC Ferrite cores are certified to ASTM A1009-05.** Statistical test data of the critical magnetic characteristics measured on each manufacturing order are supplied with each shipment.
4. **Informative website www.tscinternational.com**
Company and product information and engineering tools including calculators for core parameters, core loss density, dc bias and inductance index (A_L values).
3. **Fast, flexible process and company culture** enables us to make and supply customers what they need on short (lead time) notice.
2. **Purchase cores 24/7, 365 days/year** through our Internet direct sales channel with no minimums.
www.tscinternational.net
1. **TSC Ferrite International is your only source for NAFTA made low loss ferrites.**

39105 North Magnetics Boulevard Wadsworth Illinois 60063

Phone 847-249-4800, Fax 847-249-4888,

www.tscinternational.com